



Manual Fotográfico de Quantificação de Alimentos IAN-AF 2015-2016

Autores: Duarte Torres, Nuno Faria, Nataline Sousa, Sérgio Teixeira, Rita Soares, Hélder Amorim, Sofia Guiomar, Liliane Lobato, Catarina Oliveira, Daniela Correia, Catarina Carvalho, Sofia Vilela, Milton Severo, Carla Lopes.

Título: Inquérito Alimentar Nacional e de Atividade Física, IAN-AF 2015-2016: Manual Fotográfico de Quantificação de Alimentos.

Autores: Duarte Torres, Nuno Faria, Nataline Sousa, Sérgio Teixeira, Rita Soares, Hélder Amorim, Sofia Guiomar, Liliane Lobato, Catarina Oliveira, Daniela Correia, Catarina Carvalho, Sofia Vilela, Milton Severo, Carla Lopes.

Edição: Universidade do Porto

ISBN: 978-989-746-182-8

Todos os direitos estão reservados. Este manual destina-se exclusivamente às atividades desenvolvidas no âmbito do IAN-AF. As imagens apresentadas neste manual estão protegidas pelo código do direito de autor e direitos conexos. Não pode ser reproduzido, exibido, publicado ou redistribuído sem a prévia autorização dos autores. Os pedidos de autorização devem ser endereçados para geral@ian-af.up.pt.

IAN-AF 2015-2016 (www.ian-af.up.pt)

Sugestão de citação: Torres D, Faria N, Sousa N, Teixeira S, Soares R, Amorim H, Guiomar S, Lobato L, Oliveira C, Correia D, Carvalho C, Vilela S, Severo M, Lopes C. Inquérito Alimentar Nacional e de Atividade Física, IAN-AF 2015-2016: Manual Fotográfico de Quantificação de Alimentos. Universidade do Porto, 2017. ISBN: 978-989-746-182-8. Disponível em: www.ian-af.up.pt.

AUTORES

Duarte Torres

- Faculdade de Ciências da Nutrição e Alimentação, Universidade do Porto
- Instituto de Saúde Pública, Unidade de Investigação em Epidemiologia (EPIUnit), Universidade do Porto

Nuno Faria

- Biotempo – Consultoria em Biotecnologia Lda.

Nataline Sousa

- Consultora independente

Sérgio Teixeira

- Biotempo – Consultoria em Biotecnologia Lda.

Rita Soares

- Estudante do Mestrado em Comunicação Clínica, Faculdade de Medicina, Universidade do Porto

Hélder Amorim

- Consultor independente

Sofia Guiomar

- Unidade de Promoção da Saúde, Departamento de Promoção da Saúde e Doenças Crónicas, Instituto Nacional de Saúde Doutor Ricardo Jorge

Liliane Lobato

- Faculdade de Ciências da Nutrição e Alimentação, Universidade do Porto

Ana Catarina Oliveira

- Faculdade de Ciências da Nutrição e Alimentação, Universidade do Porto

Daniela Correia

- Departamento Ciências da Saúde Pública e Forenses, e Educação Médica - Unidade de Epidemiologia, Faculdade de Medicina da Universidade do Porto
- Instituto de Saúde Pública, Unidade de Investigação em Epidemiologia (EPIUnit), Universidade do Porto

Ana Catarina Carvalho

- Faculdade de Ciências da Nutrição e Alimentação, Universidade do Porto
- Instituto de Saúde Pública, Unidade de Investigação em Epidemiologia (EPIUnit), Universidade do Porto

Sofia Vilela

- Departamento Ciências da Saúde Pública e Forenses, e Educação Médica - Unidade de Epidemiologia, Faculdade de Medicina da Universidade do Porto
- Instituto de Saúde Pública, Unidade de Investigação em Epidemiologia (EPIUnit), Universidade do Porto

Milton Severo

- Departamento Ciências da Saúde Pública e Forenses, e Educação Médica - Unidade de Epidemiologia, Unidade de Educação Médica, Faculdade de Medicina da Universidade do Porto
- Instituto de Saúde Pública, Unidade de Investigação em Epidemiologia (EPIUnit), Universidade do Porto

Carla Lopes

- Departamento Ciências da Saúde Pública e Forenses, e Educação Médica - Unidade de Epidemiologia, Faculdade de Medicina da Universidade do Porto
- Instituto de Saúde Pública, Unidade de Investigação em Epidemiologia (EPIUnit), Universidade do Porto

DESENVOLVIMENTO DO MANUAL FOTOGRÁFICO DE QUANTIFICAÇÃO DE ALIMENTOS

O manual de fotográfico de quantificação de alimentos (MQA) foi desenvolvido para apoiar os participantes no Inquérito Alimentar Nacional e de Atividade Física (IAN-AF) a estimar a quantidade consumida de alimentos ou receitas. Os alimentos, as receitas e as porções selecionadas representam, com completude, o consumo alimentar em Portugal, de acordo com dados de estudos prévios, nomeadamente, o estudo EpiPorto (coorte de base-populacional de adultos do Porto), o estudo EpiTeen (*Epidemiological Health Investigation of Teenagers in Porto*) e o estudo piloto PANEU (*Pilot study in the view of a Pan-European dietary survey - adolescents, adults and elderly*). O MQA foi integrado no software eAT24 (*Electronic Assessment Tool for 24h recall*) desenvolvido para a recolha dos dados de consumo durante os questionários às 24-horas anteriores, ou dos diários alimentares, utilizado no trabalho de campo do IAN-AF.

Foram fotografadas 176 séries de 159 alimentos ou receitas e 11 séries de 32 medidas caseiras. Alguns alimentos ou receitas foram fotografados em mais que uma série, alterando o formato de apresentação (ex. a sopa foi apresentada em prato de sopa e em tijela).

O procedimento para a preparação das fotografias seguiu os princípios propostos por Crispim S, *et al.*[1] com algumas alterações na instalação do equipamento fotográfico, na definição das quantidades dos alimentos ou receitas a fotografar e na disposição dos alimentos ou receitas no prato, tal como a seguir descrito.

Em cada uma das séries fotográficas de alimentos ou receitas são geralmente apresentadas 6 fotografias, por ordem crescente de quantidade. As porções mais pequenas foram colocadas no lado direito do prato. As porções maiores foram dispostas, preferencialmente, aumentando a área do prato ocupada. No momento da quantificação, os participantes podiam selecionar a quantidade apresentada na fotografia, uma fração da quantidade apresentada (1/4, 1/2 ou 3/4) ou seus múltiplos.

Para estimar a quantidade (em gramas) de alimento ou receita em cada foto de cada série, foi necessário estabelecer uma quantidade/porção média de consumo por refeição de cada alimento ou receita (\bar{x}), tipicamente apresentada na 3ª foto da série, e a variância da quantidade consumida. Utilizou-se o valor médio, \bar{x} , estabelecido em estudos prévios (EpiPorto, EpiTeen, PANEU).

Para estimar a variância da quantidade consumida por refeição, utilizaram-se os dados de consumo obtidos em Portugal durante o estudo de validação do manual de quantificação alimentar conduzido durante o estudo PANEU [2].

Considerando que a quantidade consumida por refeição de alimento ou receita não segue uma distribuição normal, aplicou-se uma transformação Box-Cox à distribuição das quantidades consumidas. A potência estimada para a transformação foi de 0,39. Calculou-se o coeficiente de variação para as quantidades consumidas para cada alimento ou receita com a transformação Box-Cox. Estimou-se que a média dos coeficientes de variação das quantidades consumidas com a transformação Box-Cox era de 20%. Desta forma foi possível estimar os desvios-padrão das quantidades consumidas para novos alimentos/receitas a partir de \bar{x} e do coeficiente de variação médio. Fixou-se a quantidade (m) em cada fotografia (i) de cada série fotográfica com um aumento de 20% relativamente à porção média após transformação Box-Cox, em que i toma valor 1,2,...,6 fotografias (Equação 1). Desta forma, o aumento da quantidade de uma fotografia para a seguinte corresponde a um desvio-padrão. As quantidades estimadas em cada fotografia podiam ser ligeiramente alteradas para facilitar o trabalho de construção dos pratos a fotografar. Quando o empratamento não era exequível, por ser muito pequena ou muito grande a quantidade a empratar estimada, essa fotografia era retirada da série.

$$m_i = \left(\bar{x}^{0.39} - \frac{3-i}{5} \times \bar{x}^{0.39} \right)^{\frac{1}{0.39}} \quad \text{Equação 1.}$$

Como o objetivo das imagens produzidas foi apoiar os participantes do inquérito na estimativa das quantidades ingeridas de cada alimento, as imagens foram concebidas de forma a darem uma perceção do prato o mais próxima possível daquela que um ser humano teria ao olhar para o mesmo numa situação em que estivesse sentado à mesa com o prato à sua frente. Para tal, a imagem fotográfica deve ser obtida com uma lente que tenha um ângulo de abertura próximo dos 45°. A Figura 1 ilustra a posição da máquina fotográfica, numa perspetiva de planta. Tal como se pode ver nesta figura, a máquina foi colocada a cerca de 42 cm de distância do centro do prato. Foi usada uma distância focal que conferia às imagens uma largura do campo representado de 35 cm, à distância do centro do prato (ponto de focagem). A máquina foi colocada num tripé, a 42 cm de altura em relação ao plano dos pratos. As fotografias foram tiradas com a abertura da lente regulada para f8 de forma a garantir uma profundidade de campo suficientemente grande para garantir uma imagem focada tanto na parte mais próxima do prato como na mais afastada.

Foram utilizadas duas fontes de luz artificial, com uma temperatura de cor próxima da luz de dia. A luz foi filtrada por um tecido translúcido de cor branca que envolveu a zona a fotografar, criando uma “caixa” com um volume adequado para não interferir na imagem. As fontes de luz foram colocadas lateralmente, ligeiramente desfasadas em relação à sua distância à máquina fotográfica e ao prato a fotografar. Conseguiu-se, assim, iluminar toda a área a fotografar, criando apenas uma ligeira sombra nos alimentos. As fontes de iluminação foram sempre as mesmas, colocadas sempre na mesma posição, em todas as imagens criadas.

Os objetos a fotografar foram colocados sobre um tecido de cor creme que permitiu criar algum contraste de forma a ser perceptível o limite dos pratos. Este fundo imita o efeito visual de uma toalha de mesa genérica, sem qualquer elemento visual que possa perturbar a perceção da quantidade de alimento em cada imagem.

O recipiente escolhido para criar a imagem de cada prato foi aquele que seria normal utilizar para servir a iguaria em questão. Foram colocados na imagem os talheres que normalmente seriam utilizados com o alimento em questão para servirem de referência dimensional. Os serviços de talheres e recipientes utilizados foram adquiridos numa casa especializada na venda de material de hotelaria. Foram escolhidos os serviços com maior volume de vendas.

O prato raso, prato de sopa e prato de sobremesa utilizados tinham cerca de 27, 23 e 20,5 cm de diâmetro, respetivamente.



Figura 1 – Representação esquemática, em planta, da posição da máquina fotográfica em relação ao objeto fotografado

Os alimentos e as receitas foram fotografados logo após a sua preparação/confeção e empratamento. A informação relativa ao modo de preparação e aos ingredientes das receitas foi recolhida em livros de gastronomia, sites de gastronomia e em fichas técnicas de várias

unidades de alimentação coletiva e restauração. Sempre que possível, as receitas foram retiradas do livro *Cozinha Tradicional Portuguesa* [3].

Na secção III. Quantidades, são apresentadas as quantidades dos alimentos ou das receitas tal como apresentados nas fotografias (Tabela 1) e as respetivas quantidades edíveis (Tabela 2). É também apresentada a composição nutricional (energia, proteína, hidratos de carbono, açúcares, gordura, ácidos gordos saturados e fibra) de cada porção fotografada (Tabela 3). Por fim, são apresentados os volumes das medidas caseiras (Tabela 4).

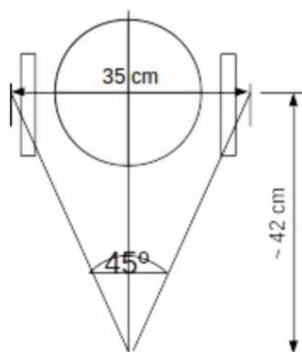
Para o cálculo da composição nutricional dos alimentos utilizou-se a Tabela de Composição de Alimentos [4] ampliada durante o IAN-AF. Para o cálculo da composição nutricional das receitas partiu-se da composição dos seus ingredientes crus. Considerou-se ainda o valor da fração edível dos ingredientes e o rendimento do método de confeção das receitas [5].

Este manual servirá para dar apoio a inquéritos da mesma natureza em populações de língua portuguesa, e poderá ainda ser utilizado por profissionais da área da nutrição e da saúde em geral para apoio a atividades da área clínica ou da alimentação coletiva.

REFERÊNCIAS

1. Crispim S, Nicolas G, Freisling H, Slimani N. (2011) Preparation of Photos for Food Portion Quantification in EPIC-Soft – Reference Guidelines. Lyon: IARC.
2. Vilela S, Lopes C, Guiomar S, Severo M, Rangelova L, Petrova S, Horváth S, Cseh J, Schwe-ter A, Lindtner O, Ambrus A, Torres, D. (2018) Validation of a picture book to be used in a pan-European dietary survey. *Public Health Nutrition*, 21(9), 1654-1663. doi:10.1017/S1368980017004153
3. Maria de Lourdes Modesto, “Cozinha Tradicional Portuguesa”, Editorial Verbo, 18ª edição (1989).
4. Tabela de Composição de Alimentos Portuguesa, Instituto Nacional de Saúde Doutor Ricardo Jorge (2006).
5. Reinivuo H, Bell S, Ovaskainen MJ. (2009) Harmonisation of recipe calculation procedures in European food composition databases. *Journal of Food Composition and Analysis*, 22, 410-413.

ÍNDICE

Autores	4
Desenvolvimento do Manual Fotográfico de Quantificação de Alimentos	5
Índice	9
I. Alimentos e receitas	14
Fruta, hortícolas e leguminosas	15
MQA001 Espinafres, folhas verdes, cozidos	16
MQA002 Couve, folhas verdes, cozida	17
MQA003 Couve-flor, cozida	18
MQA004 Alho-francês, cozido	19
MQA005 Agrião, folhas verdes, cru	20
MQA006 Feijão-verde, vagem, cozido	21
MQA007 Curgete, rodela, cozida	22
MQA008 Cenoura, rodela, cozida	23
MQA011 Cenoura, ralada, crua	24
MQA009 Pimento, cozido	25
MQA010 Tomate, rodela, cru	26
MQA012 Brócolos, cozidos	27
MQA013 Couve-de-bruxelas, cozidas	28
MQA015 Beringela, rodela, no forno	29
MQA016 Pepino, rodela, cru	30
MQA018 Salada verde	31
MQA019 Salada verde, mista	32
MQA149 Salada de couve-roxa, crua	33
MQA024 Puré de vegetais, esparregado	34
MQA109 Gratinado de vegetais	35
MQA025 Leguminosas, feijão, cozido	36
MQA017 Ervilhas, cozidas	37
MQA161 Macedónia, cozida	38
MQA034 Tremoços, prato de sobremesa	39
MQA035 Tremoços, taça	40
MQA020 Sopa, prato	41
MQA021 Sopa, tijela	42
MQA031 Azeitonas, prato de sobremesa	43
MQA032 Azeitonas, taça	44
MQA036 Salada de fruta, taça	45
MQA037A Morangos, taça	46
MQA037B Morangos, prato de sobremesa	47
MQA038A Uvas, prato de sobremesa	48
MQA038B Uvas, taça	49
MQA039 Cerejas, prato de sobremesa	50
MQA039B Cerejas, taça	51
MQA040 Melão	52

MQA042	Meloa	53
MQA043	Melancia	54
MQA044	Manga	55
MQA045	Ananás	56
MQA065	Papa de fruta, prato	57
MQA065B	Papa de fruta, taça	58
MQA046A	Frutos gordos s/casca, nozes, prato de sobremesa	59
MQA046B	Frutos gordos s/casca, nozes, taça	60
MQA046C	Frutos gordos c/casca, amendoim, prato de sobremesa	61
MQA046D	Frutos gordos c/casca, amendoim, taça	62
MQA046E	Frutos gordos s/casca, amendoim, prato de sobremesa	63
MQA046F	Frutos gordos s/casca, amendoim, taça	64
MQA046G	Frutos gordos c/casca, pistácio, prato de sobremesa	65
MQA046H	Frutos gordos c/casca, pistácio, taça	66
MQA047	Castanhas	67
Cereais, derivados e tubérculos		68
MQA056	Cereais, cornflakes, taça	69
MQA055	Cereais, cornflakes, prato	70
MQA057	Cereais, “fitness”, special K, taça	71
MQA058	Cereais, “fitness”, special K, prato	72
MQA059A	Cereais, muesli, taça	73
MQA059B	Cereais, muesli, prato	74
MQA060	Cereais, “chocapic”, taça	75
MQA061	Cereais, “chocapic”, prato	76
MQA062	Pão, fatias	77
MQA062B	Pão, inteiro	78
MQA062C	Broa, de milho, de Avintes, pedaços	79
MQA063A	Farinha láctea, “cerelac”, prato	80
MQA063B	Farinha Láctea, “cerelac”, taça	81
MQA064	Nestum, prato	82
MQA069	Batata, pedaços, cozida	83
MQA112	Salada russa	84
MQA070	Batata frita, palitos	85
MQA071	Batata frita, pacote	86
MQA154	Puré de batata	87
MQA072	Massa, cozida	88
MQA073	Esparguete, cozido	89
MQA076	Massa chinesa, cozida	90
MQA148	Massa com vegetais	91
MQA077	Arroz branco, cozido	92
MQA078	Arroz de ervilhas	93
MQA080	Arroz malandro	94
MQA145	Migas, c/ grelos	95
MQA084	Açorda alentejana, tipo migas	96
Carne, pescado e ovos		97
MQA052	Presunto, fatias	98

MQA053 Fiambre, fatias	99
MQA054 Chouriço, linguiça, rodelas	100
MQA085 Bife	101
MQA087 Carne, pedaços, cozida	102
MQA088 Carne, com ervilhas e cenouras, estufada	103
MQA104 Jardineira, batata e carne estufada	104
MQA105 Chili	105
MQA086 Costeleta, com osso, grelhada	106
MQA159 Entremeada	107
MQA162 Entrecosto	108
MQA155 Espetadas mistas, c/ espeto	109
MQA155B Espetadas mistas, s/ espeto	110
MQA089 Carne, fatias, assada	111
MQA163 Rolo de Carne	112
MQA157 Panados de carne	113
MQA091 Rojões	114
MQA102 Bifanas	115
MQA100 Tripas à moda do Porto	116
MQA110 Feijoada de carnes	117
MQA103 Carne de porco à Alentejana	118
MQA106 Strogonoff de carne	119
MQA107 Carne, com batatas, estufada	120
MQA090 Frango, assado	121
MQA099 Frango estufado, c/ molho	122
MQA101B Moelas, c/ molho	123
MQA111 Cozido à Portuguesa	124
MQA144 Migas, à alentejana	125
MQA093 Rancho	126
MQA153 Massa com carne ou peixe	127
MQA097 Empadão de carne	128
MQA074 Esparguete, bolonhesa	129
MQA075 Esparguete, carbonara	130
MQA081 Lasanha	131
MQA082 Ravioli	132
MQA113 Peixe, filete	133
MQA114 Peixe, postas finas	134
MQA115 Peixe, postas grossas	135
MQA121 Peixes pequenos, fritos	136
MQA122 Peixe, inteiro, grelhado	137
MQA126 Caldeirada de peixe	138
MQA116 Bacalhau com cebolada	139
MQA117 Bacalhau com grão de bico	140
MQA118 Bacalhau com natas	141
MQA119 Bacalhau espiritual	142
MQA120 Bacalhau à Gomes de Sá	143
MQA156 Pataniscas de bacalhau	144
MQA098 Bacalhau, à Brás	145

MQA092 Roupas velhas	146
MQA123 Mexilhão, s/ concha	147
MQA123B Mexilhão, s/ concha, c/ molho	148
MQA123C Mexilhão, c/ concha	149
MQA123D Mexilhão, c/ concha, c/molho	150
MQA124 Camarão	151
MQA108 Chop suey	152
MQA125 Calamares	153
MQA129 Lulas, grelhadas	154
MQA127 Lulas estufadas, com legumes	155
MQA128 Polvo, cozido	156
MQA079 Arroz de polvo	157
MQA152 Arroz de peixe	158
MQA146 Tortilha	159
MQA147A Ovos mexidos	160
Produtos lácteos	161
MQA026 Queijo fresco, feta, tofu, fatias	162
MQA027 Queijo fresco, inteiro	163
MQA028 Requeijão, inteiro	164
MQA029 Queijo saloio	165
MQA048 Queijo brie, queijo camembert	166
MQA049 Queijo da ilha, queijo manchego	167
MQA050 Queijo chèvre, rolo, fatias	168
MQA051 Queijo flamengo, fatias	169
Manteiga e compota	170
MQA066 Manteiga	171
MQA067 Manteiga, em pão	172
MQA068A Doce, Compota, pão	173
MQA068B Doce, Compota, prato	174
Bolos e outros doces	175
MQA130 Bolo leve, pão de ló	176
MQA131 Bolo denso, de ananás	177
MQA132 Bolo rei	178
MQA140 Bolo de bolacha	179
MQA133 Tarte fina	180
MQA134 Tarte alta, c/ fruta	181
MQA135 Torta, fatias redondas	182
MQA136 Gelado, "viennetta", fatias	183
MQA137 Pudim	184
MQA138 Leite creme	185
MQA139 Mousse, prato	186
MQA139B Mousse, taça	187
MQA141 Aletria, prato	188
MQA142 Aletria, prato de sobremesa	189
MQA143 Pipocas	190

Outras receitas e alimentos compostos	191
MQA094 Quiche	192
MQA095 Bola de carne, fatias	193
MQA096 Tarte salgada, empada	194
MQA151 Calzone	195
MQA150A Pizza grande	196
MQA150B Pizza média	197
II. Medidas Caseiras	198
MC01 – Copos de vinho com pé e copos cálice (balão)	199
MC02 – Copo de vinho e cálices conhaque	199
MC03 – Copo executivo, copos de vinho e flute	200
MC04 – Copos viticole, copo de vinho e copo com pé	200
MC05 – Copos de cerveja	201
MC06 – Copo <i>long drink</i> (tipo longo), <i>on the rocks</i> (tipo curto) e copo <i>shot</i>	201
MC07 – Copos sem pé	202
MC08 – Chávena de café, de chá e de meia de leite	202
MC09 – Caneca, chávena de chá e de meia de leite	203
MC010 – Tigelas de sopa e taça de vidro	203
MC011 – Tigela de sopa e taças de vidro	204
III. Quantidades	205
Tabela 1. Peso total	206
Tabela 2. Peso edível	210
Tabela 3. Composição nutricional	214
Tabela 4. Volume das medidas caseiras	239

I. Alimentos e receitas

Fruta, hortícolas e leguminosas

MQA001 Espinafres, folhas verdes, cozidos



MQA001-A



MQA001-B



MQA001-C



MQA001-D



MQA001-E



MQA001-F

MQA002 Couve, folhas verdes, cozida



MQA002-A



MQA002-B



MQA002-C



MQA002-D



MQA002-E



MQA002-F

MQA003 Couve-flor, cozida

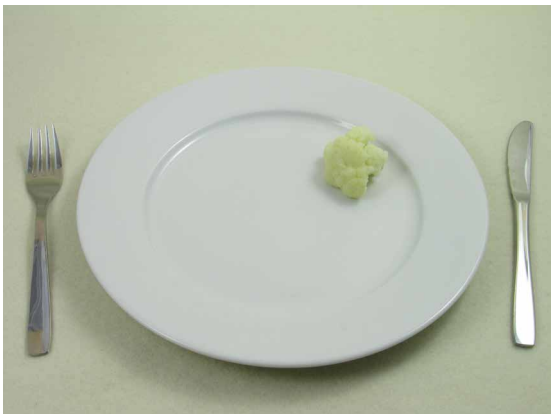

MQA003-A



MQA003-B



MQA003-C

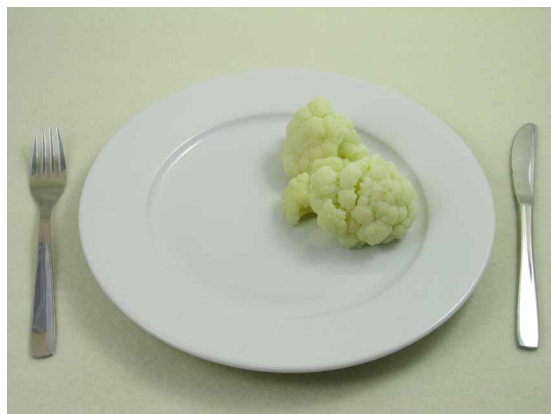

MQA003-D



MQA003-E



MQA003-F

MQA004 Alho-francês, cozido



MQA004-A



MQA004-B



MQA004-C



MQA004-D



MQA004-E



MQA004-F

MQA005 Agrião, folhas verdes, cru



MQA005-A



MQA005-B



MQA005-C



MQA005-D



MQA005-E



MQA005-F

MQA006 Feijão-verde, vagem, cozido



MQA006-A



MQA006-B

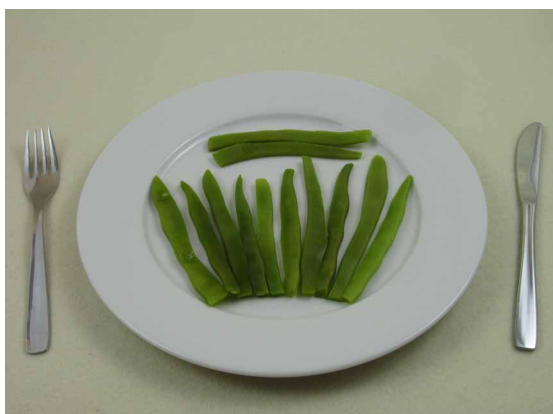

MQA006-C



MQA006-D



MQA006-E



MQA006-F

MQA007 Curgete, rodela, cozida



MQA007-A



MQA007-B

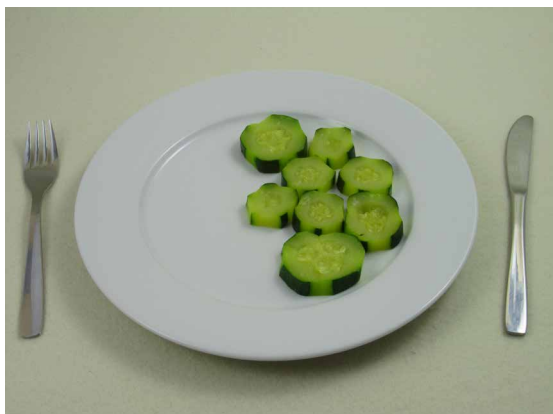

MQA007-C



MQA007-D



MQA007-E

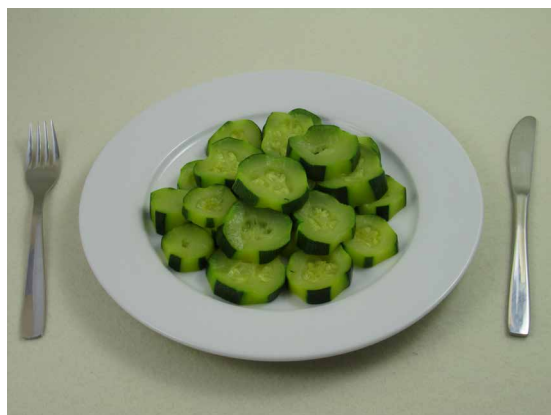

MQA007-F

MQA008 Cenoura, rodela, cozida



MQA008-A



MQA008-B



MQA008-C



MQA008-D



MQA008-E



MQA008-F

MQA011 Cenoura, ralada, crua



MQA011-A



MQA011-B



MQA011-C



MQA011-D



MQA011-E



MQA011-F

MQA009 Pimento, cozido



MQA009-A



MQA009-B



MQA009-C



MQA009-D



MQA009-E



MQA009-F

MQA010 Tomate, rodela, cru



MQA010-A



MQA010-B

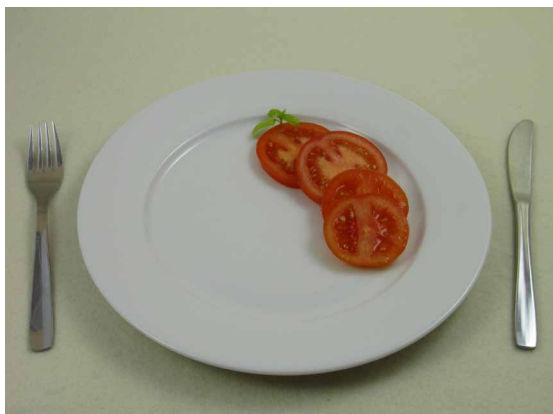

MQA010-C

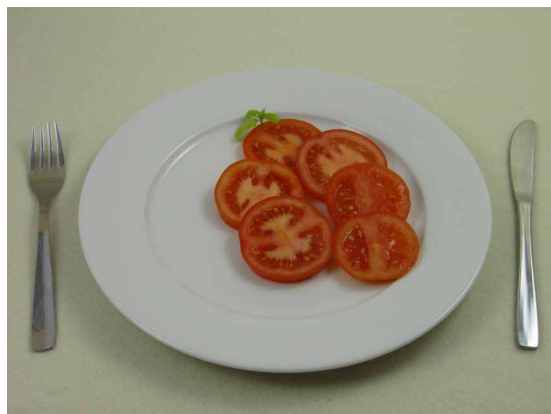

MQA010-D



MQA010-E



MQA010-F

MQA012 Brócolos, cozidos



MQA012-A



MQA012-B



MQA012-C



MQA012-D



MQA012-E

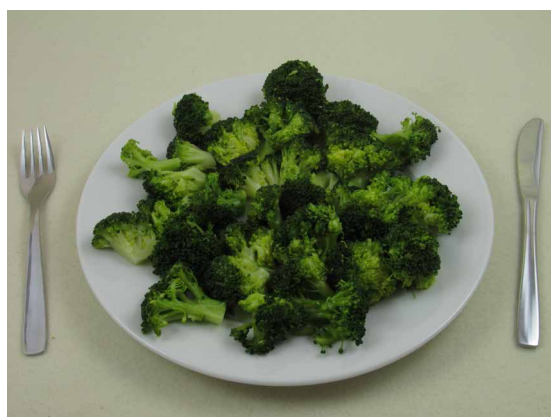

MQA012-F

MQA013 Couve-de-bruxelas, cozidas



MQA013-A



MQA013-B



MQA013-C



MQA013-D



MQA013-E



MQA013-F

MQA015 Beringela, rodela, no forno



MQA015-A



MQA015-B



MQA015-C



MQA015-D



MQA015-E



MQA015-F

MQA016 Pepino, rodelas, cru



MQA016-A

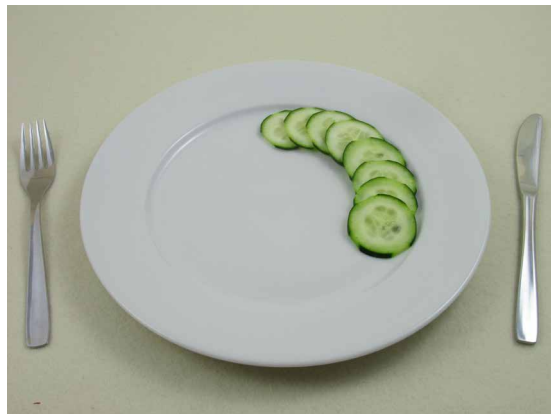

MQA016-B

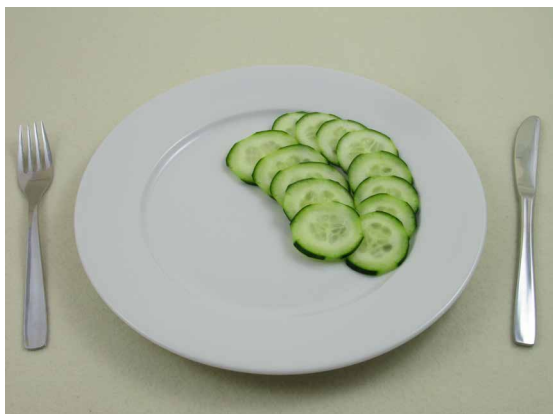

MQA016-C

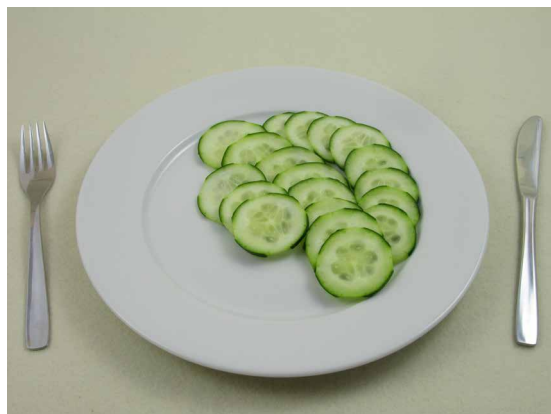

MQA016-D

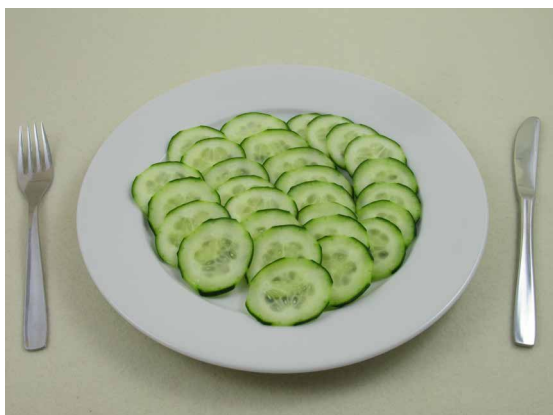

MQA016-E

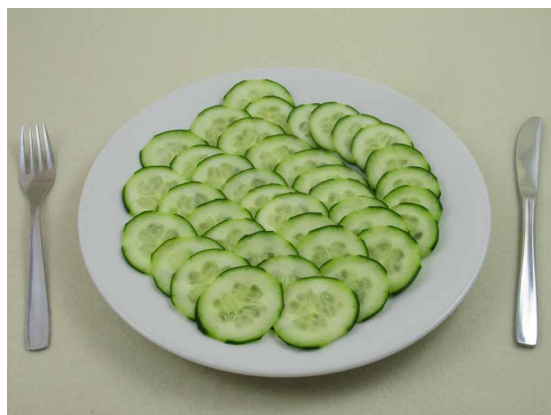

MQA016-F

MQA018 Salada verde



MQA018-A



MQA018-B



MQA018-C



MQA018-D



MQA018-E



MQA018-F

MQA019 Salada verde, mista



MQA019-A



MQA019-B



MQA019-C



MQA019-D



MQA019-E



MQA019-F

MQA149 Salada de couve-roxa, crua



MQA149-A



MQA149-B



MQA149-C



MQA149-D



MQA149-E



MQA149-F

MQA024 Puré de vegetais, esparregado



MQA024-A



MQA024-B



MQA024-C



MQA024-D



MQA024-E



MQA024-F



MQA024-G

MQA109 Gratinado de vegetais



MQA109-A



MQA109-B



MQA109-C



MQA109-D



MQA109-E



MQA109-F

MQA025 Leguminosas, feijão, cozido



MQA025-A



MQA025-B



MQA025-C



MQA025-D



MQA025-E



MQA025-F

MQA017 Ervilhas, cozidas



MQA017-A



MQA017-B



MQA017-C



MQA017-D



MQA017-E



MQA017-F

MQA161 Macedónia, cozida



MQA161-A



MQA161-B



MQA161-C



MQA161-D



MQA161-E



MQA161-F

MQA020 Sopa, prato



MQA020-A



MQA020-B



MQA020-C



MQA020-D



MQA020-E

MQA021 Sopa, tijela



MQA021-A



MQA021-B



MQA021-C



MQA021-D



MQA021-E

MQA031 Azeitonas, prato de sobremesa



MQA031-A



MQA031-B



MQA031-C



MQA031-D



MQA031-E



MQA031-F

MQA032 Azeitonas, taça



MQA032-A



MQA032-B



MQA032-C



MQA032-D



MQA032-E



MQA032-F

MQA034 Tremoços, prato de sobremesa



MQA034-A



MQA034-B



MQA034-C



MQA034-D



MQA034-E



MQA034-F

MQA035 Tremoços, taça



MQA035-A



MQA035-B



MQA035-C



MQA035-D



MQA035-E



MQA035-F

MQA036 Salada de fruta, taça



MQA036-A



MQA036-B



MQA036-C



MQA036-D

MQA037A Morangos, taça



MQA037A-A



MQA037A-B



MQA037A-C



MQA037A-D



MQA037A-E



MQA037A-F

MQA037B Morangos, prato de sobremesa



MQA037B-A



MQA037B-B



MQA037B-C



MQA037B-D



MQA037B-E



MQA037B-F

MQA038A Uvas, prato de sobremesa



MQA038A-A



MQA038A-B



MQA038A-C



MQA038A-D



MQA038A-E



MQA038A-F

MQA038B Uvas, taça



MQA038B-A



MQA038B-B



MQA038B-C



MQA038B-D



MQA038B-E



MQA038B-F

MQA039 Cerejas, prato de sobremesa



MQA039-A



MQA039-B

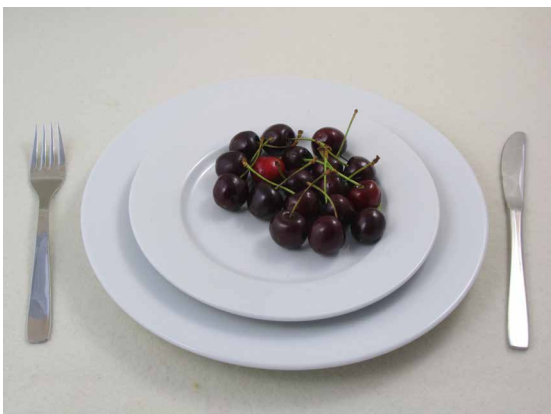

MQA039-C



MQA039-D



MQA039-E



MQA039-F

MQA039B Cerejas, taça



MQA039B-A



MQA039B-B



MQA039B-C



MQA039B-D



MQA039B-E

MQA040 Melão

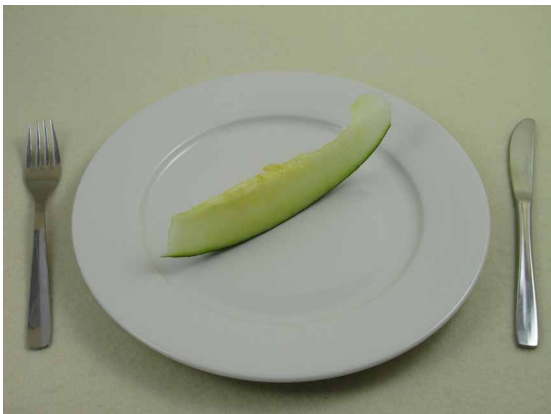

MQA040-A

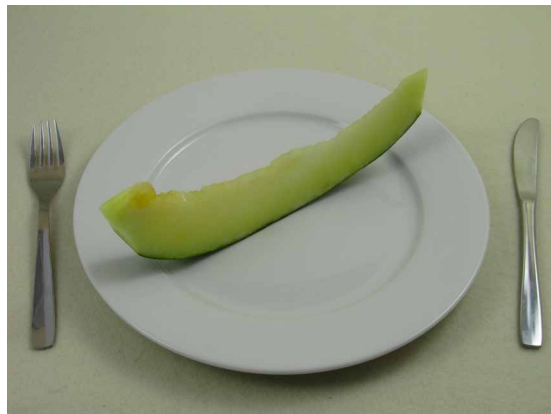

MQA040-B

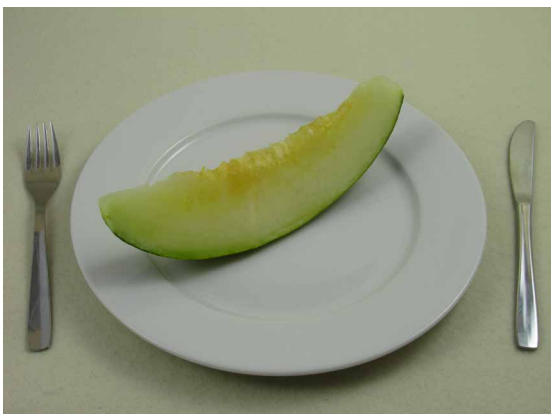

MQA040-C

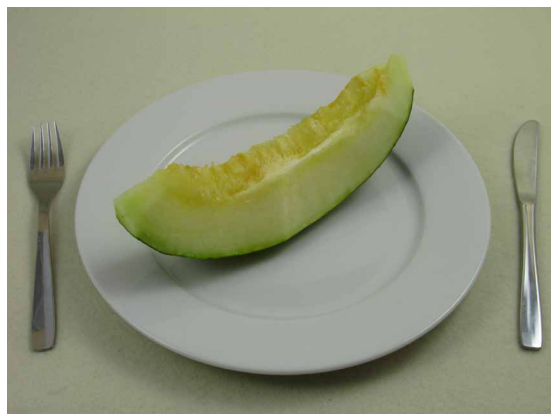

MQA040-D

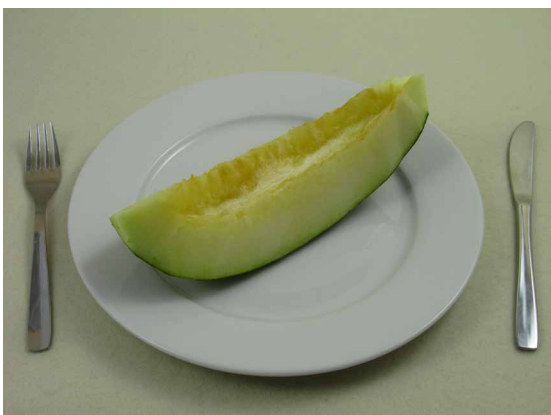

MQA040-E



MQA040-F

MQA042 Meloa

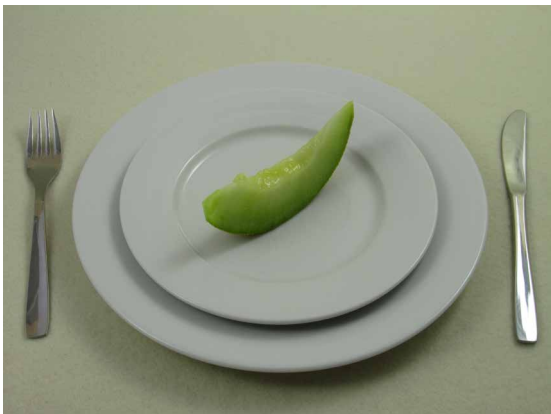

MQA042-A

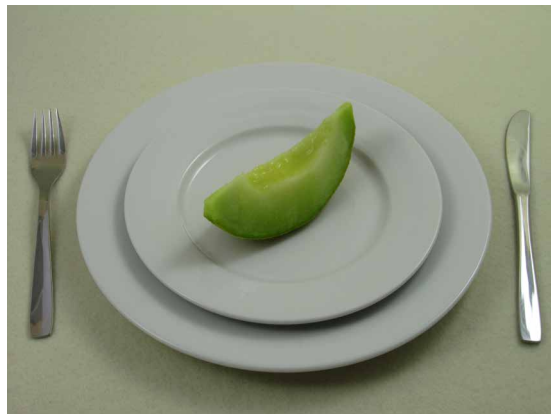

MQA042-B



MQA042-C



MQA042-D



MQA042-E

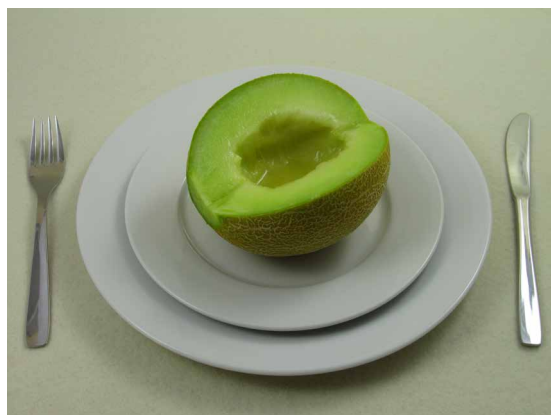

MQA042-F

MQA043 Melancia

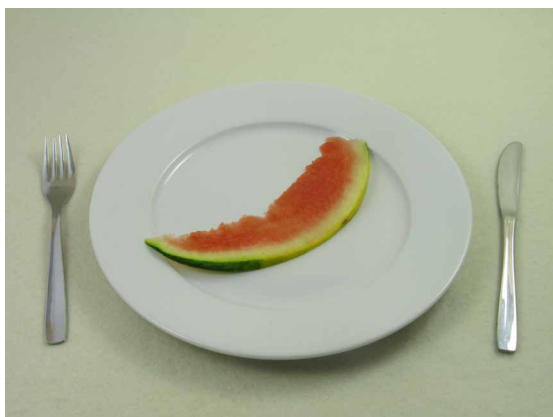

MQA043-A

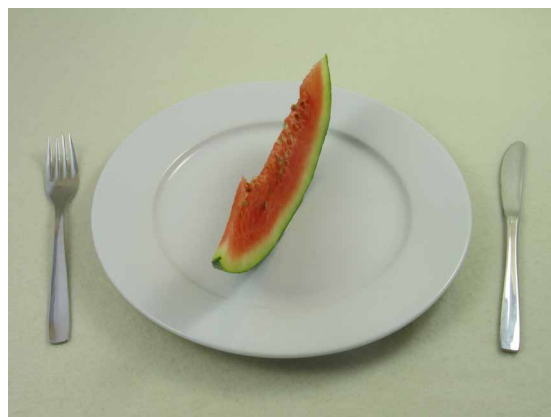

MQA043-B

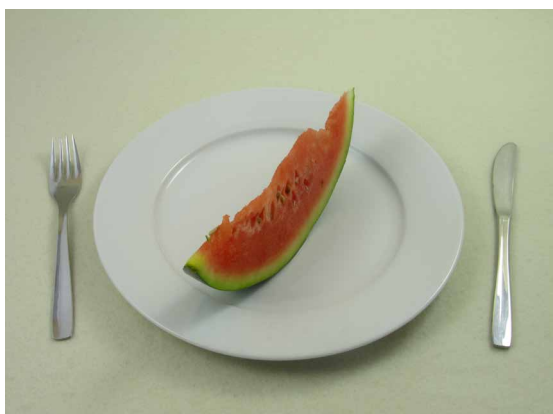

MQA043-C

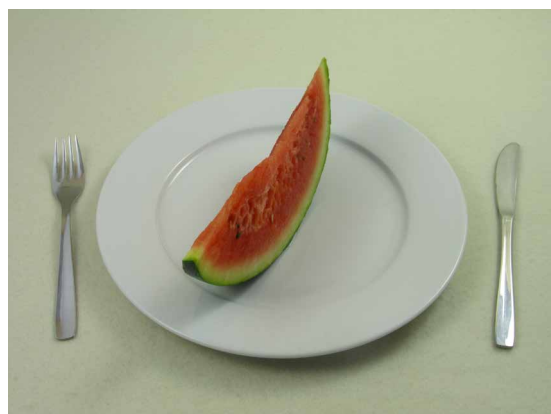

MQA043-D

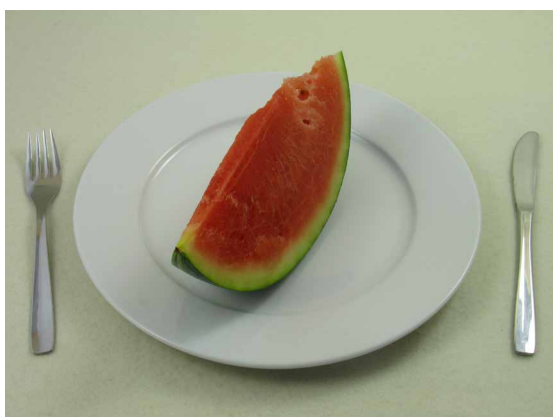

MQA043-E



MQA043-F

MQA044 Manga

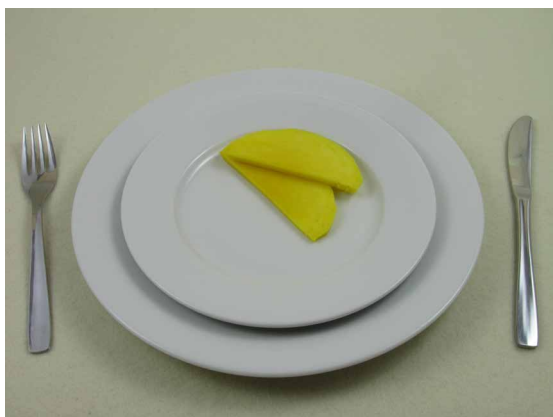

MQA044-A

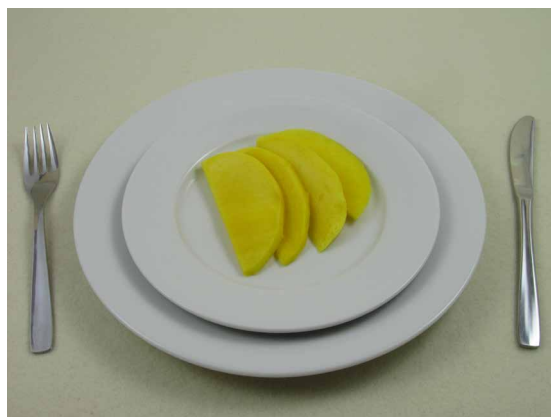

MQA044-B

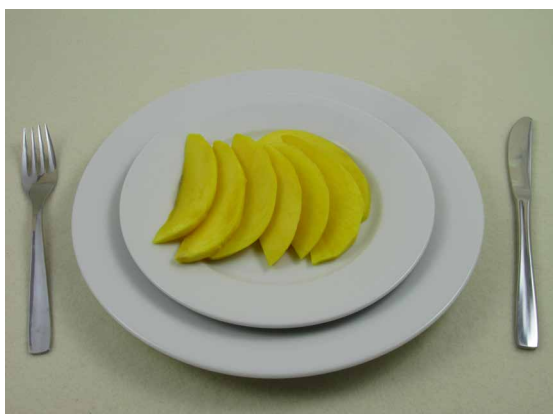

MQA044-C



MQA044-D



MQA044-E



MQA044-F

MQA045 Ananás



MQA045-A

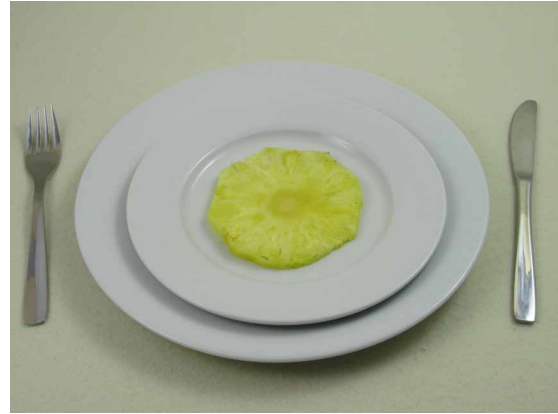

MQA045-B



MQA045-C



MQA045-D

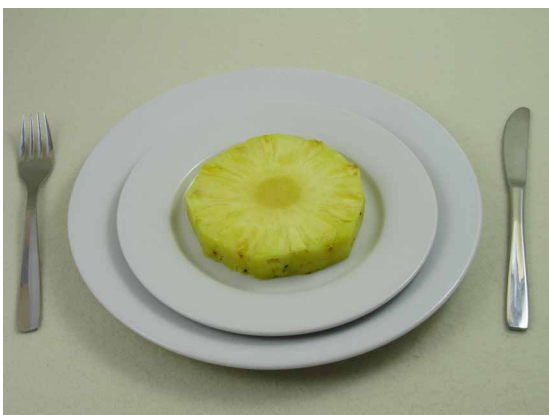

MQA045-E



MQA045-F

MQA065 Papa de fruta, prato



MQA065-A



MQA065-B



MQA065-C



MQA065-D



MQA065-E

MQA065B Papa de fruta, taça



MQA065B-A



MQA065B-B



MQA065B-C



MQA065B-D



MQA065B-E

MQA046A Frutos gordos s/casca, nozes, prato de sobremesa



MQA046A-A



MQA046A-B



MQA046A-C



MQA046A-D



MQA046A-E



MQA046A-F

MQA046B Frutos gordos s/casca, nozes, taça



MQA046B-A



MQA046B-B



MQA046B-C



MQA046B-D



MQA046B-E

MQA046C Frutos gordos c/casca, amendoim, prato de so-



MQA046C-A



MQA046C-B



MQA046C-C



MQA046C-D



MQA046C-E



MQA046C-F

MQA046D Frutos gordos c/casca, amendoim, taça



MQA046D-A



MQA046D-B



MQA046D-C



MQA046D-D

MQA046E Frutos gordos s/casca, amendoim, prato de so-



MQA046E-A



MQA046E-B



MQA046E-C



MQA046E-D



MQA046E-E



MQA046E-F

MQA046F Frutos gordos s/casca, amendoim, taça



MQA046F-A



MQA046F-B



MQA046F-C



MQA046F-D



MQA046F-E



MQA046F-F

MQA046G Frutos gordos c/casca, pistácio, prato de sobremesa



MQA046G-A



MQA046G-B



MQA046G-C



MQA046G-D



MQA046G-E



MQA046G-F

MQA046H Frutos gordos c/casca, pistácio, taça



MQA046H-A



MQA046H-B



MQA046H-C



MQA046H-D



MQA046H-E



MQA046H-F

MQA047 Castanhas



MQA047-A



MQA047-B



MQA047-C



MQA047-D



MQA047-E



MQA047-F

Cereais, derivados e tubérculos

MQA056 Cereais, cornflakes, taça



MQA056-A



MQA056-B



MQA056-C



MQA056-D



MQA056-E

MQA055 Cereais, cornflakes, prato



MQA055-A



MQA055-B



MQA055-C



MQA055-D



MQA055-E

MQA057 Cereais, “fitness”, special K, taça



MQA057-A



MQA057-B



MQA057-C



MQA057-D



MQA057-E

MQA058 Cereais, “fitness”, special K, prato



MQA058-A



MQA058-B



MQA058-C



MQA058-D



MQA058-E

MQA059A Cereais, muesli, taça



MQA059A-A



MQA059A-B



MQA059A-C



MQA059A-D



MQA059A-E

MQA059B Cereais, muesli, prato



MQA059B-A



MQA059B-B



MQA059B-C



MQA059B-D



MQA059B-E

MQA060 Cereais, “chocapic”, taça



MQA060-A



MQA060-B



MQA060-C



MQA060-D



MQA060-E



MQA060-F

MQA061 Cereais, “chocapic”, prato



MQA061-A



MQA061-B



MQA061-C



MQA061-D



MQA061-E



MQA061-F

MQA062 Pão, fatias



MQA062-A



MQA062-B



MQA062-C



MQA062-D



MQA062-E



MQA062-F



MQA062-G



MQA062-H

MQA062B Pão, inteiro



MQA062B-A



MQA062B-B

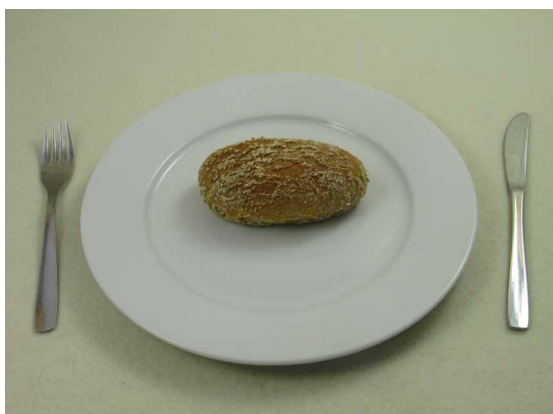

MQA062B-C



MQA062B-D



MQA062B-E



MQA062B-F

MQA062C Broa, de milho, de Avintes, pedaços



MQA062C-A



MQA062C-B



MQA062C-C

MQA063A Farinha láctea, “cerelac”, prato



MQA063A-A



MQA063A-B



MQA063A-C



MQA063A-D



MQA063A-E

MQA063B Farinha Láctea, “cerelac”, taça



MQA063B-A



MQA063B-B



MQA063B-C



MQA063B-D



MQA063B-E

MQA064 Nestum, prato



MQA064-A



MQA064-B



MQA064-C



MQA064-D



MQA064-E

MQA069 Batata, pedaços, cozida



MQA069-A



MQA069-B

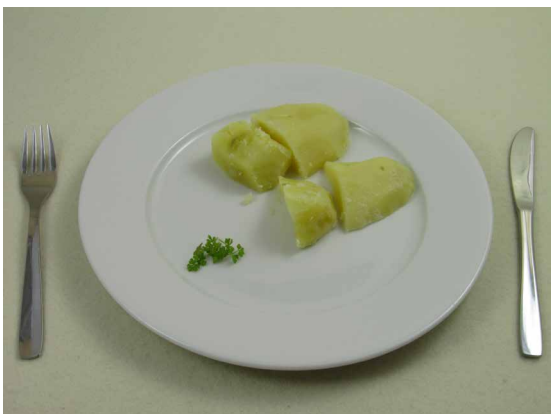

MQA069-C

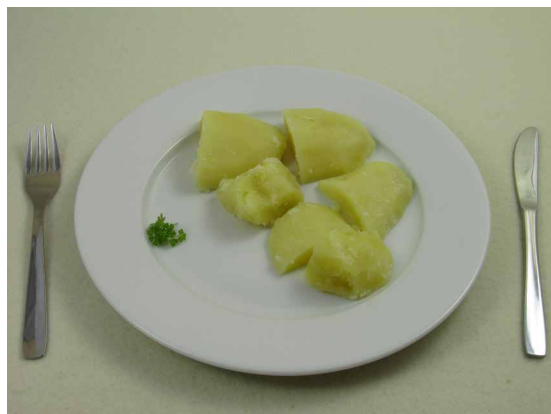

MQA069-D



MQA069-E



MQA069-F

MQA112 Salada russa



MQA112-A



MQA112-B



MQA112-C



MQA112-D



MQA112-E



MQA112-F

MQA070 Batata frita, palitos



MQA070-A



MQA070-B



MQA070-C



MQA070-D



MQA070-E



MQA070-F

MQA071 Batata frita, pacote



MQA071-A



MQA071-B



MQA071-C



MQA071-D



MQA071-E



MQA071-F

MQA154 Puré de batata

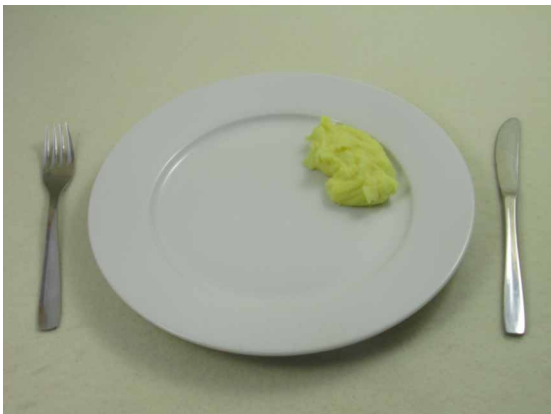

MQA154-A

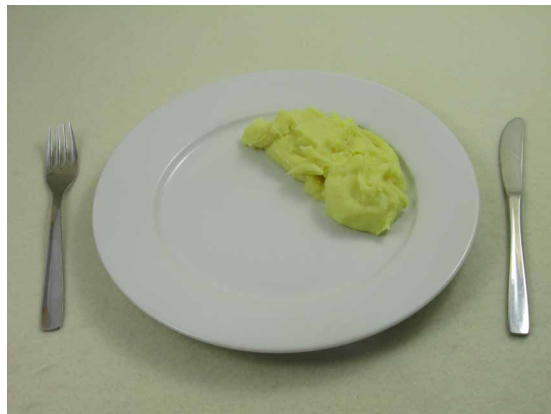

MQA154-B

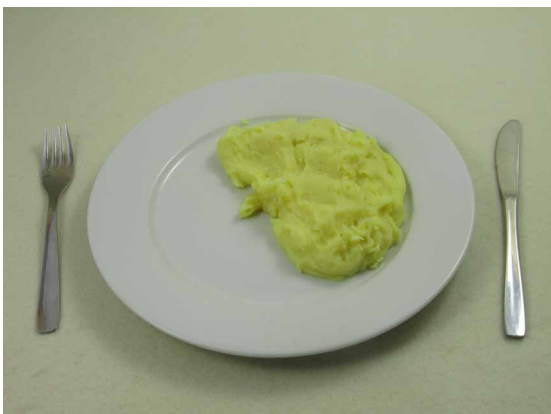

MQA154-C



MQA154-D



MQA154-E



MQA154-F

MQA072 Massa, cozida



MQA072-A



MQA072-B



MQA072-C



MQA072-D



MQA072-E



MQA072-F

MQA073 Esparguete, cozido



MQA073-A



MQA073-B



MQA073-C



MQA073-D



MQA073-E



MQA073-F

MQA076 Massa chinesa, cozida

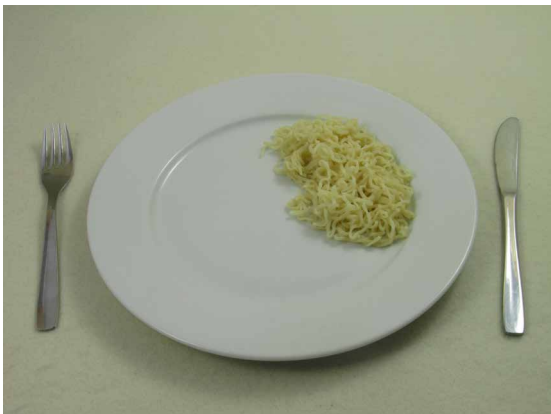

MQA076-A



MQA076-B



MQA076-C



MQA076-D



MQA076-E



MQA076-F

MQA148 Massa, com vegetais



MQA148-A



MQA148-B



MQA148-C



MQA148-D



MQA148-E



MQA148-F

MQA077 Arroz branco, cozido



MQA077-A



MQA077-B



MQA077-C



MQA077-D



MQA077-E



MQA077-F

MQA078 Arroz de ervilhas



MQA078-A



MQA078-B



MQA078-C



MQA078-D



MQA078-E



MQA078-F

MQA080 Arroz malandro



MQA080-A



MQA080-B



MQA080-C



MQA080-D



MQA080-E



MQA080-F

MQA145 Migas, c/ grelos



MQA145-A



MQA145-B



MQA145-C



MQA145-D



MQA145-E



MQA145-F

MQA084 Açorda alentejana, tipo migas



MQA084-A



MQA084-B



MQA084-C



MQA084-D



MQA084-E



MQA084-F

Carne, pescado e ovos

MQA052 Presunto, fatias



MQA052-A



MQA052-B



MQA052-C



MQA052-D



MQA052-E

MQA053 Fiambre, fatias



MQA053-A



MQA053-B



MQA053-C



MQA053-D



MQA053-E

MQA054 Chouriço, linguiça, rodelas



MQA054-A



MQA054-B



MQA054-C



MQA054-D



MQA054-E



MQA054-F

MQA085 Bife

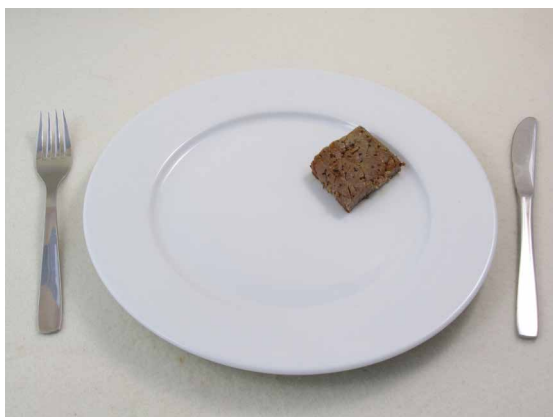

MQA085-A

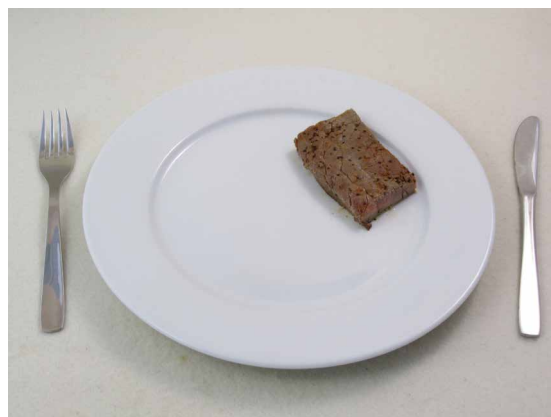

MQA085-B

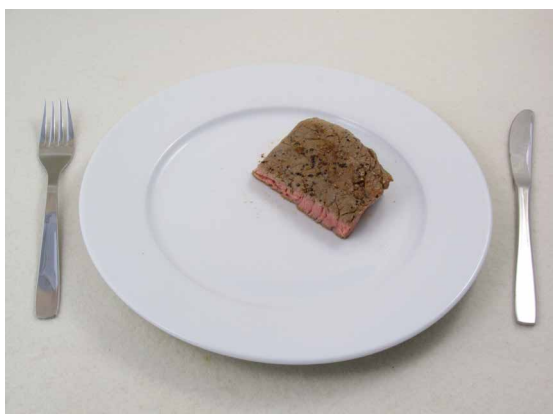

MQA085-C

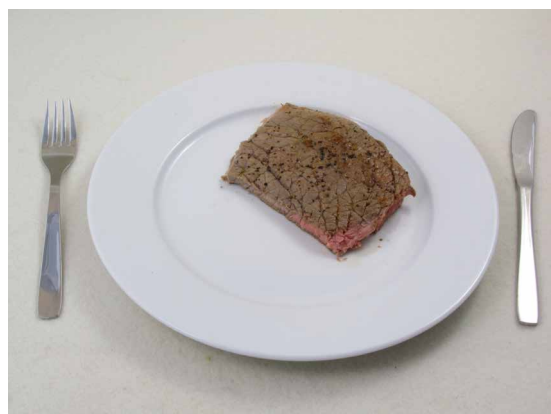

MQA085-D



MQA085-E

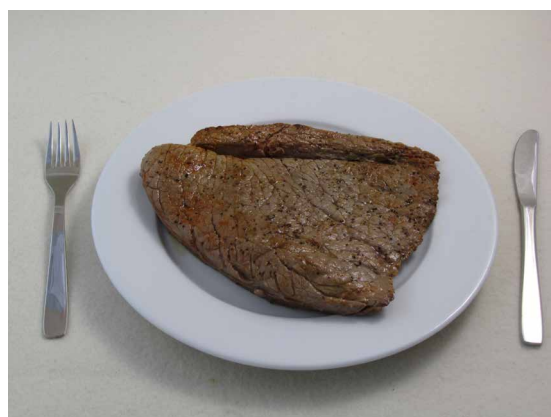

MQA085-F

MQA087 Carne, pedaços, cozida



MQA087-A



MQA087-B



MQA087-C



MQA087-D



MQA087-E



MQA087-F

MQA088 Carne, com ervilhas e cenouras, estufada



MQA088-A



MQA088-B



MQA088-C



MQA088-D



MQA088-E



MQA088-F

MQA104 Jardineira, batata e carne estufada



MQA104-A



MQA104-B



MQA104-C



MQA104-D



MQA104-E



MQA104-F

MQA105 Chili



MQA105-A



MQA105-B



MQA105-C



MQA105-D



MQA105-E



MQA105-F

MQA086 Costeleta, com osso, grelhada



MQA086-A



MQA086-B



MQA086-C



MQA086-D



MQA086-E



MQA086-F

MQA159 Entremeada



MQA159-A



MQA159-B



MQA159-C



MQA159-D



MQA159-E



MQA159-F



MQA159-G

MQA162 Entrecosto



MQA162-A



MQA162-B



MQA162-C



MQA162-D



MQA162-E



MQA162-F

MQA155 Espetadas mistas, c/ espeto



MQA155-A



MQA155-B



MQA155-C



MQA155-D



MQA155-E

MQA155B Espetadas mistas, s/ espeto



MQA155B-A



MQA155B-B



MQA155B-C



MQA155B-D



MQA155B-E

MQA089 Carne, fatias, assada

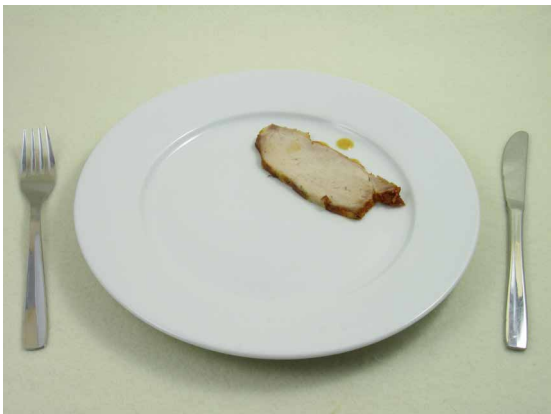

MQA089-A

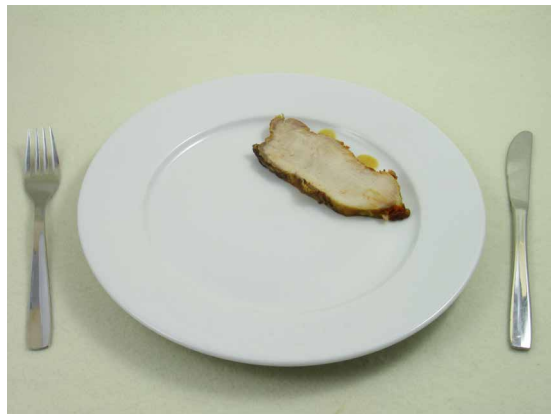

MQA089-B



MQA089-C

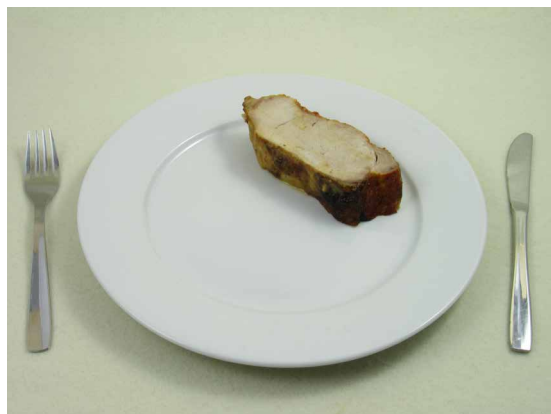

MQA089-D



MQA089-E



MQA089-F

MQA163 Rolo de Carne



MQA163-A



MQA163-B



MQA163-C



MQA163-D



MQA163-E



MQA163-F

MQA157 Panados de carne



MQA157-A



MQA157-B



MQA157-C



MQA157-D



MQA157-E



MQA157-F

MQA091 Rojões



MQA091-A



MQA091-B



MQA091-C



MQA091-D



MQA091-E

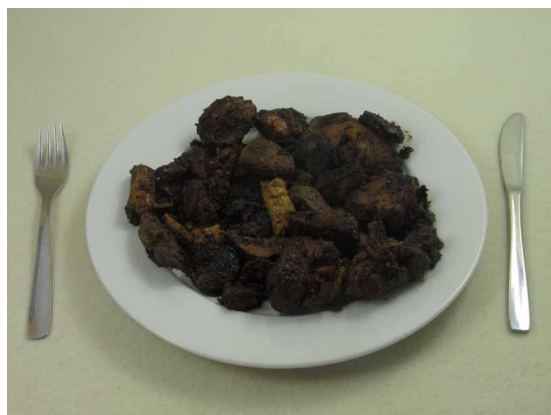

MQA091-F

MQA102 Bifanas



MQA102-A



MQA102-B



MQA102-C



MQA102-D



MQA102-E



MQA102-F

MQA100 Tripas à moda do Porto



MQA100-A



MQA100-B



MQA100-C



MQA100-D



MQA100-E



MQA100-F

MQA110 Feijoada de carnes



MQA110-A



MQA110-B



MQA110-C



MQA110-D



MQA110-E



MQA110-F

MQA103 Carne de porco à Alentejana



MQA103-A



MQA103-B



MQA103-C



MQA103-D



MQA103-E



MQA103-F

MQA106 Strogonoff de carne



MQA106-A



MQA106-B



MQA106-C



MQA106-D



MQA106-E



MQA106-F

MQA107 Carne, com batatas, estufada



MQA107-A



MQA107-B



MQA107-C



MQA107-D



MQA107-E



MQA107-F

MQA090 Frango, assado



MQA090-A



MQA090-B



MQA090-C



MQA090-D



MQA090-E



MQA090-F

MQA099 Frango estufado, c/ molho



MQA099-A



MQA099-B



MQA099-C



MQA099-D



MQA099-E



MQA099-F

MQA101B Moelas, c/ molho



MQA101B-A



MQA101B-B



MQA101B-C



MQA101B-D



MQA101B-E



MQA101B-F

MQA111 Cozido à Portuguesa



MQA111-A



MQA111-B



MQA111-C



MQA111-D



MQA111-E

MQA144 Migas, à alentejana



MQA144-A



MQA144-B



MQA144-C



MQA144-D



MQA144-E



MQA144-F

MQA093 Rancho



MQA093-A



MQA093-B



MQA093-C



MQA093-D



MQA093-E

MQA153 Massa com carne ou peixe



MQA153-A



MQA153-B



MQA153-C



MQA153-D



MQA153-E



MQA153-F

MQA097 Empadão de carne

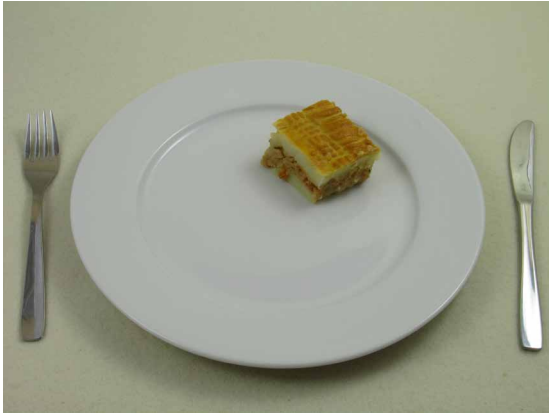

MQA097-A



MQA097-B



MQA097-C



MQA097-D



MQA097-E

MQA074 Esparguete, bolonhesa



MQA074-A



MQA074-B



MQA074-C



MQA074-D



MQA074-E



MQA074-F

MQA075 Esparguete, carbonara



MQA075-A



MQA075-B



MQA075-C



MQA075-D



MQA075-E



MQA075-F

MQA081 Lasanha



MQA081-A



MQA081-B



MQA081-C



MQA081-D



MQA081-E



MQA081-F

MQA082 Ravioli



MQA082-A



MQA082-B



MQA082-C



MQA082-D



MQA082-E



MQA082-F

MQA113 Peixe, filete



MQA113-A



MQA113-B



MQA113-C



MQA113-D



MQA113-E

MQA114 Peixe, postas finas



MQA114-A



MQA114-B

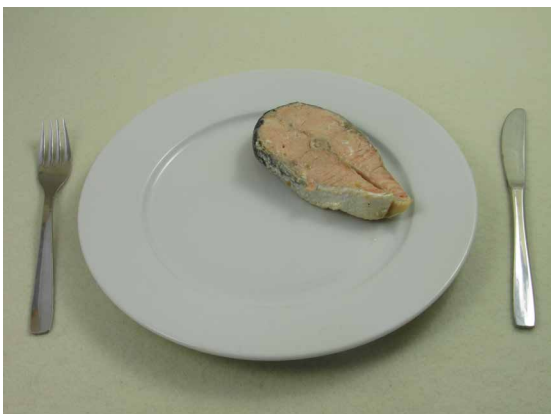

MQA114-C

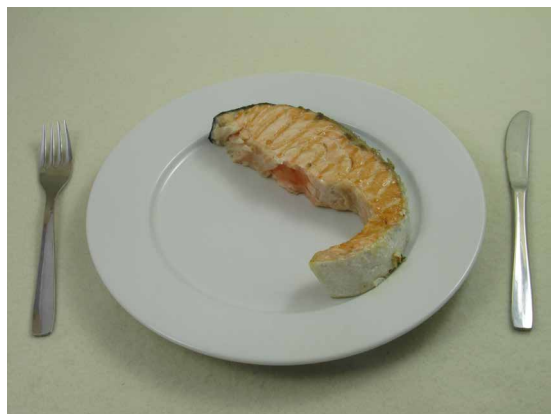

MQA114-D



MQA114-E



MQA114-F

MQA115 Peixe, postas grossas



MQA115-A



MQA115-B



MQA115-C



MQA115-D

MQA121 Peixes pequenos, fritos



MQA121-A



MQA121-B



MQA121-C



MQA121-D



MQA121-E



MQA121-F

MQA122 Peixe, inteiro, grelhado



MQA122-A



MQA122-B



MQA122-C

MQA126 Caldeirada de peixe



MQA126-A



MQA126-B



MQA126-C



MQA126-D



MQA126-E



MQA126-F

MQA116 Bacalhau com cebolada



MQA116-A



MQA116-B



MQA116-C



MQA116-D



MQA116-E



MQA116-F

MQA117 Bacalhau com grão de bico



MQA117-A



MQA117-B



MQA117-C



MQA117-D



MQA117-E



MQA117-F

MQA118 Bacalhau com natas



MQA118-A



MQA118-B



MQA118-C



MQA118-D



MQA118-E



MQA118-F

MQA119 Bacalhau espiritual



MQA119-A



MQA119-B



MQA119-C



MQA119-D



MQA119-E



MQA119-F

MQA120 Bacalhau à Gomes de Sá



MQA120-A



MQA120-B



MQA120-C



MQA120-D



MQA120-E



MQA120-F

MQA156 Pataniscas de bacalhau



MQA156-A



MQA156-B



MQA156-C



MQA156-D



MQA156-E



MQA156-F

MQA098 Bacalhau, à Brás



MQA098-A



MQA098-B



MQA098-C



MQA098-D



MQA098-E



MQA098-F

MQA092 Roupa velha



MQA092-A



MQA092-B



MQA092-C



MQA092-D



MQA092-E

MQA123 Mexilhão, s/ concha



MQA123-A



MQA123-B



MQA123-C



MQA123-D



MQA123-E



MQA123-F

MQA123B Mexilhão, s/ concha, c/ molho



MQA123B-A



MQA123B-B



MQA123B-C



MQA123B-D



MQA123B-E



MQA123B-F

MQA123C Mexilhão, c/ concha



MQA123C-A



MQA123C-B



MQA123C-C



MQA123C-D



MQA123C-E



MQA123C-F

MQA123D Mexilhão, c/ concha, c/molho



MQA123D-A



MQA123D-B



MQA123D-C



MQA123D-D



MQA123D-E



MQA123D-F

MQA124 Camarão



MQA124-A



MQA124-B



MQA124-C



MQA124-D



MQA124-E



MQA124-F



MQA124-G

MQA108 Chop suey



MQA108-A



MQA108-B



MQA108-C



MQA108-D



MQA108-E

MQA125 Calamares



MQA125-A



MQA125-B



MQA125-C



MQA125-D



MQA125-E



MQA125-F

MQA127 Lulas estufadas, com legumes



MQA127-A



MQA127-B



MQA127-C



MQA127-D



MQA127-E



MQA127-F

MQA128 Polvo, cozido



MQA128-A



MQA128-B



MQA128-C



MQA128-D



MQA128-E



MQA128-F

MQA079 Arroz de polvo



MQA079-A



MQA079-B



MQA079-C



MQA079-D



MQA079-E

MQA129 Lulas, grelhadas



MQA129-A



MQA129-B



MQA129-C



MQA129-D



MQA129-E



MQA129-F

MQA152 Arroz de peixe



MQA152-A



MQA152-B



MQA152-C



MQA152-D



MQA152-E



MQA152-F

MQA146 Tortilha



MQA146-A



MQA146-B



MQA146-C



MQA146-D



MQA146-E



MQA146-F

MQA147A Ovos mexidos



MQA147A-A



MQA147A-B



MQA147A-C



MQA147A-D



MQA147A-E



MQA147A-F

Produtos lácteos

MQA026 Queijo fresco, feta, tofu, fatias

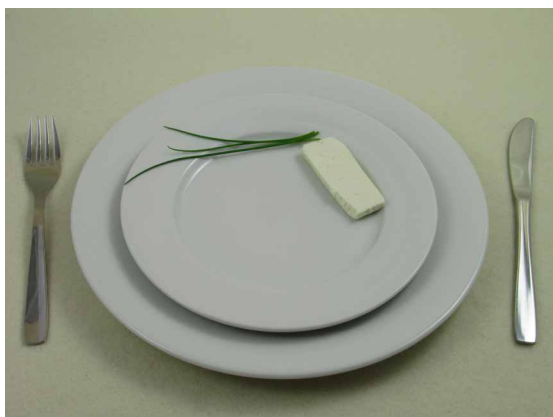

MQA026-A



MQA026-B



MQA026-C



MQA026-D



MQA026-E

MQA027 Queijo fresco, inteiro



MQA027-A



MQA027-B



MQA027-C

MQA028 Requeijão, inteiro



MQA028-A



MQA028-B



MQA028-C

MQA029 Queijo saloio

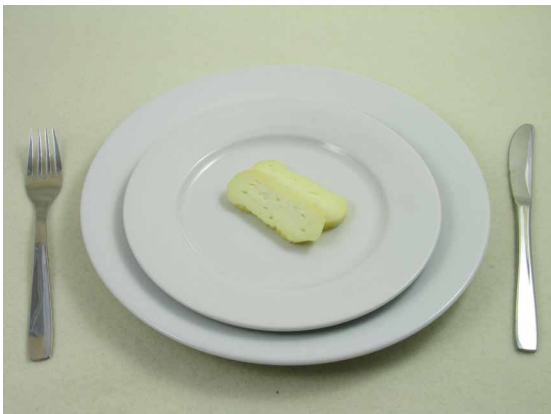

MQA029-A

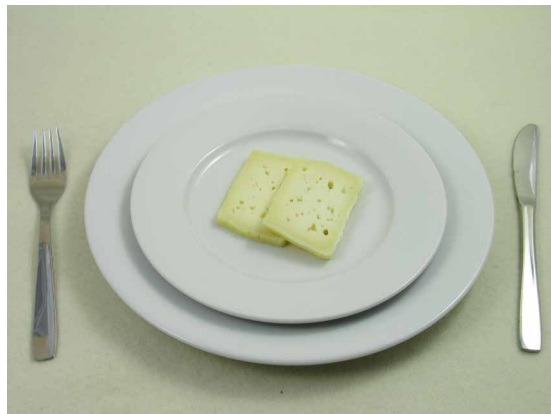

MQA029-B



MQA029-C

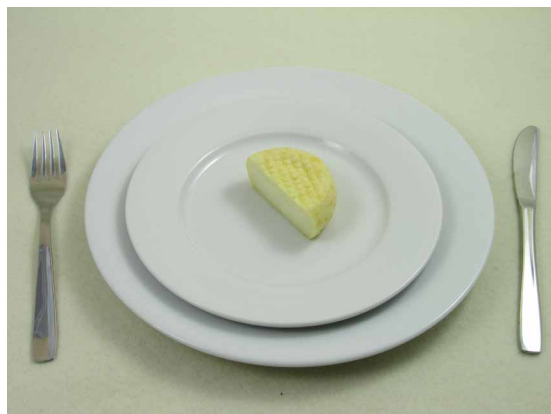

MQA029-D



MQA029-E



MQA029-F

MQA048 Queijo brie, queijo camembert



MQA048-A



MQA048-B



MQA048-C



MQA048-D



MQA048-E

MQA049 Queijo da ilha, queijo manchego

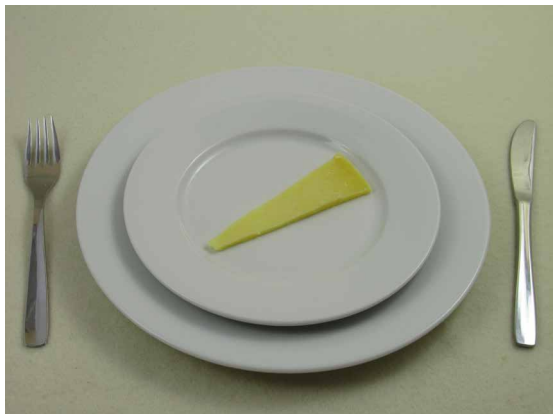

MQA049-A

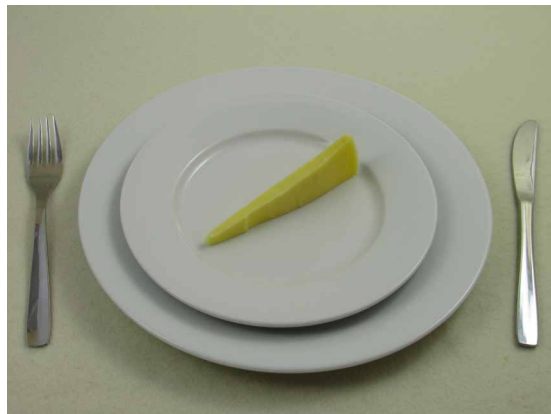

MQA049-B

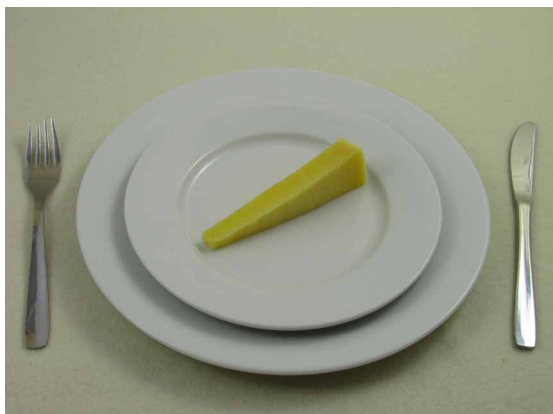

MQA049-C

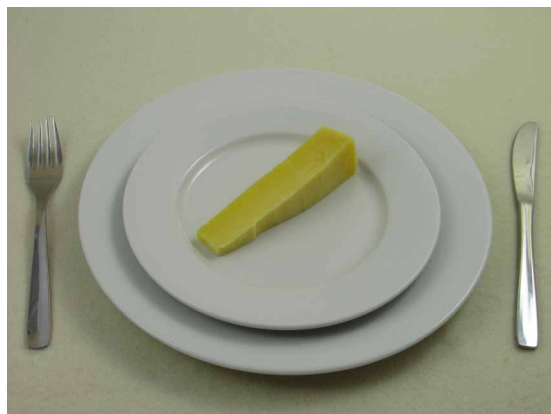

MQA049-D

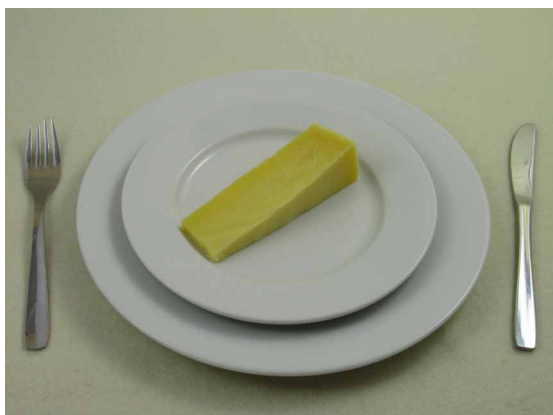

MQA049-E



MQA049-F

MQA050 Queijo chèvre, rolo, fatias



MQA050-A



MQA050-B



MQA050-C



MQA050-D



MQA050-E



MQA050-F

MQA051 Queijo flamengo, fatias



MQA051-A



MQA051-B

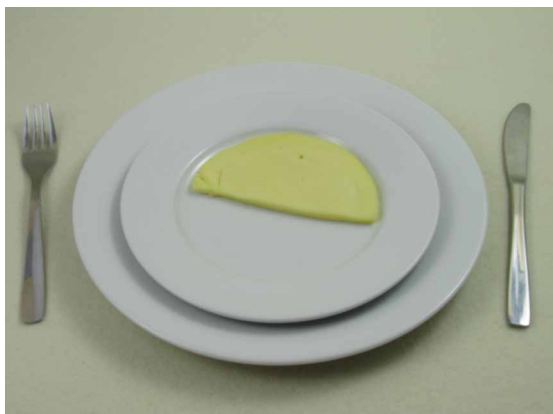

MQA051-C



MQA051-D



MQA051-E

Manteiga e compota

MQA066 Manteiga

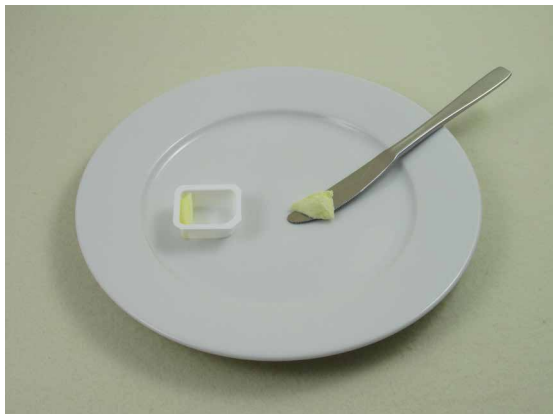

MQA066-A

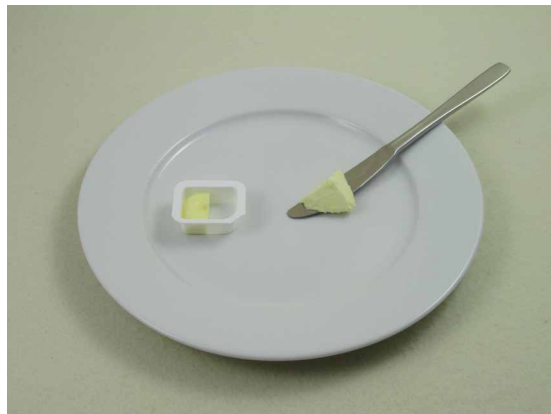

MQA066-B

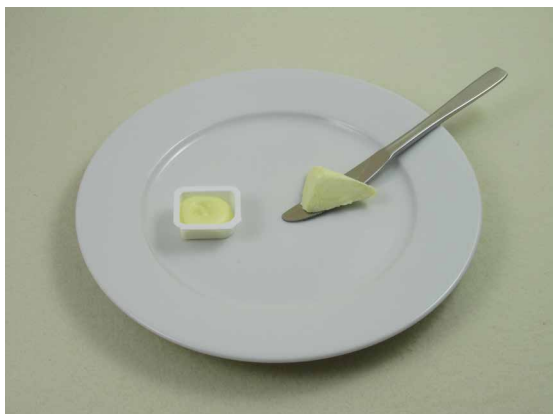

MQA066-C

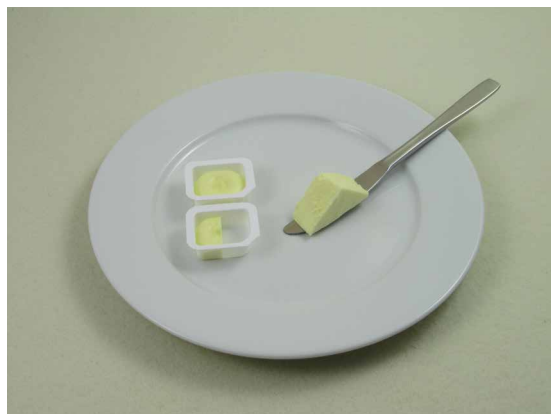

MQA066-D

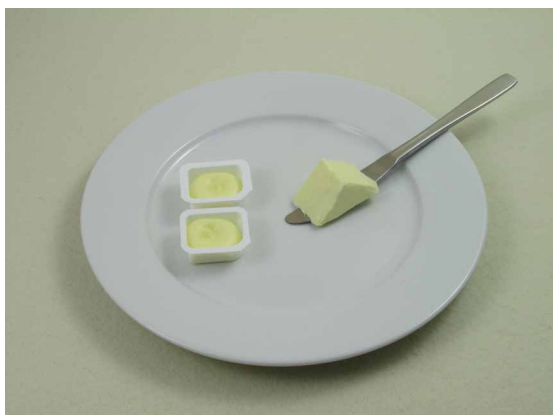

MQA066-E

MQA067 Manteiga, em pão

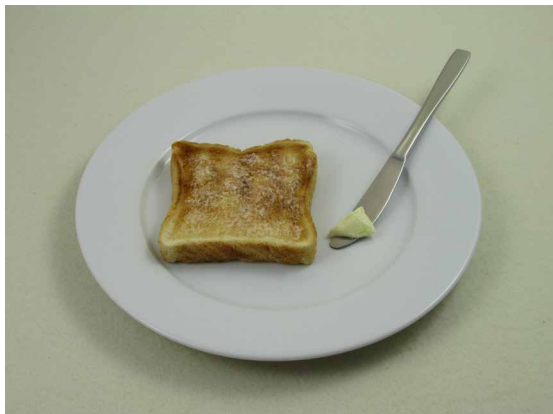

MQA067-A

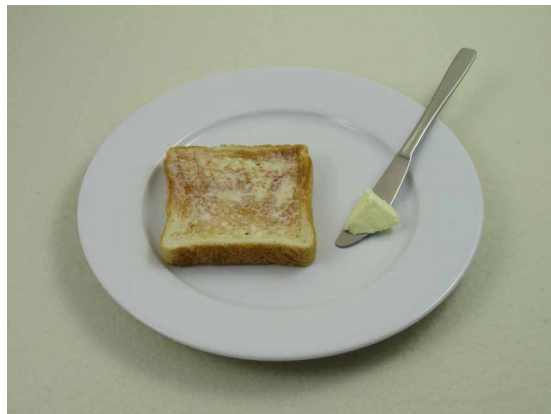

MQA067-B



MQA067-C

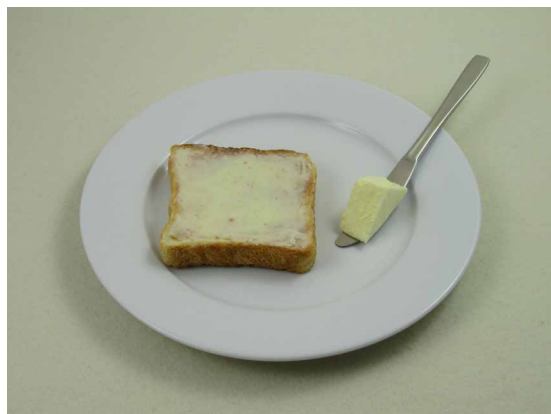

MQA067-D



MQA067-E

MQA068A Doce, Compota, pão

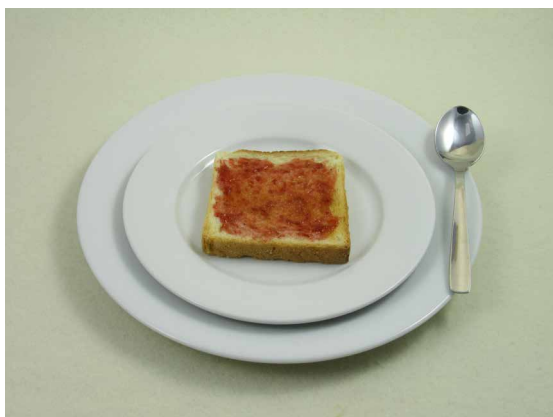

MQA068A-A

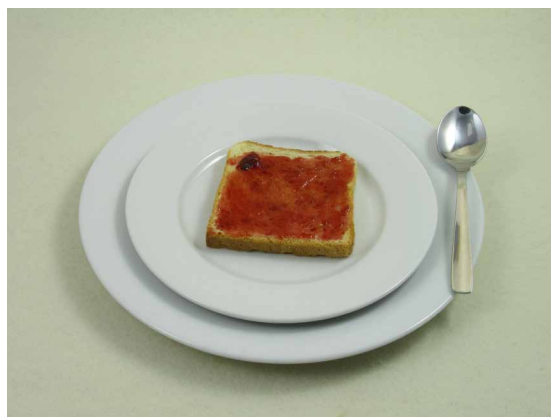

MQA068A-B

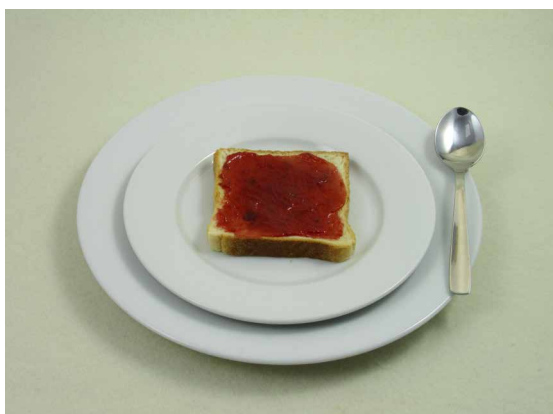

MQA068A-C

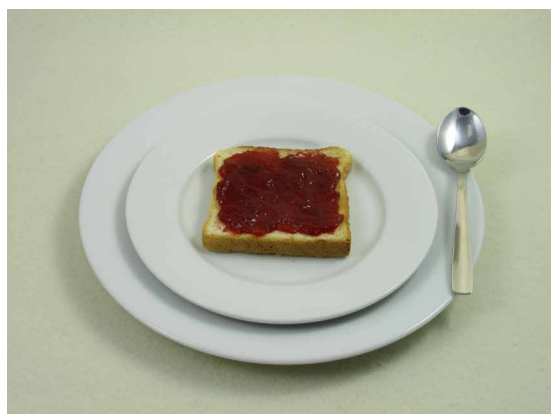

MQA068A-D



MQA068A-E

MQA068B Doce, Compota, prato



MQA068B-A



MQA068B-B



MQA068B-C



MQA068B-D



MQA068B-E

Bolos e outros doces

MQA130 Bolo leve, pão de ló



MQA130-A



MQA130-B



MQA130-C



MQA130-D



MQA130-E



MQA130-F

MQA131 Bolo denso, de ananás



MQA131-A



MQA131-B



MQA131-C



MQA131-D



MQA131-E



MQA131-F

MQA132 Bolo rei



MQA132-A



MQA132-B



MQA132-C



MQA132-D



MQA132-E



MQA132-F

MQA140 Bolo de bolacha



MQA140-A



MQA140-B



MQA140-C



MQA140-D



MQA140-E



MQA140-F

MQA133 Tarte fina



MQA133-A



MQA133-B



MQA133-C



MQA133-D



MQA133-E



MQA133-F

MQA134 Tarte alta, c/ fruta



MQA134-A



MQA134-B



MQA134-C



MQA134-D



MQA134-E



MQA134-F

MQA135 Torta, fatias redondas



MQA135-A



MQA135-B



MQA135-C



MQA135-D



MQA135-E



MQA135-F

MQA136 Gelado, “viennetta”, fatias



MQA136-A



MQA136-B



MQA136-C



MQA136-D



MQA136-E

MQA137 Pudim



MQA137-A



MQA137-B



MQA137-C



MQA137-D



MQA137-E



MQA137-F

MQA138 Leite creme



MQA138-A



MQA138-B



MQA138-C



MQA138-D



MQA138-E



MQA138-F

MQA139 Mousse, prato



MQA139-A



MQA139-B



MQA139-C



MQA139-D



MQA139-E



MQA139-F

MQA139B Mousse, taça



MQA139B-A



MQA139B-B



MQA139B-C



MQA139B-D



MQA139B-E



MQA139B-F

MQA141 Aletria, prato



MQA141-A



MQA141-B



MQA141-C



MQA141-D



MQA141-E



MQA141-F

MQA142 Aletria, prato de sobremesa



MQA142-A



MQA142-B



MQA142-C



MQA142-D



MQA142-E

MQA143 Pipocas



MQA143-A



MQA143-B



MQA143-C



MQA143-D



MQA143-E



MQA143-F

Outras receitas e alimentos compostos

MQA094 Quiche



MQA094-A



MQA094-B



MQA094-C



MQA094-D



MQA094-E



MQA094-F

MQA095 Bola de carne, fatias



MQA095-A



MQA095-B



MQA095-C



MQA095-D



MQA095-E



MQA095-F

MQA096 Tarte salgada, empada



MQA096-A



MQA096-B



MQA096-C



MQA096-D



MQA096-E



MQA096-F



MQA096-G

MQA151 Calzone



MQA151-A



MQA151-B



MQA151-C



MQA151-D

MQA150A Pizza grande



MQA150A-A



MQA150A-B



MQA150A-C



MQA150A-D



MQA150A-E

MQA150B Pizza média



MQA150B-A



MQA150B-B



MQA150B-C



MQA150B-D



MQA150B-E

II. Medidas caseiras

MC01 – Copos de vinho com pé e copos cálice (balão)



MC02 – Copo de vinho e cálices conhaque



MC03 – Copo executivo, copos de vinho e flute



MC04 – Copos viticole, copo de vinho e copo com pé



MC05 – Copos de cerveja



MC06 – Copo long drink (tipo longo), on the rocks (tipo curto) e copo shot

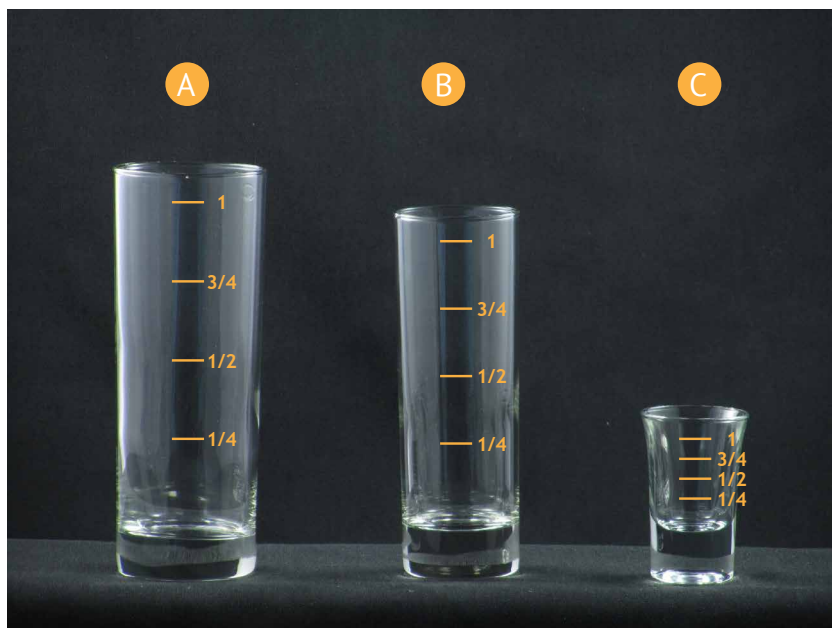

MC07 – Copos sem pé



MC08 – Chávena de café, de chá e de meia de leite

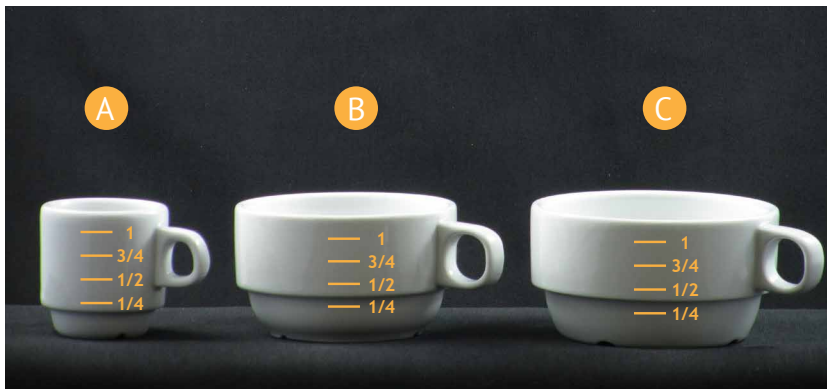

MC09 – Caneca, chávena de chá e de meia de leite



MC10 – Tigelas de sopa e taça de vidro

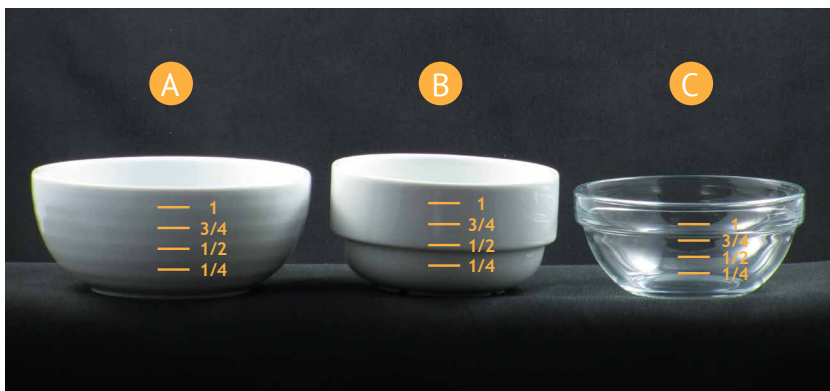

MC11 – Tigela de sopa e taças de vidro

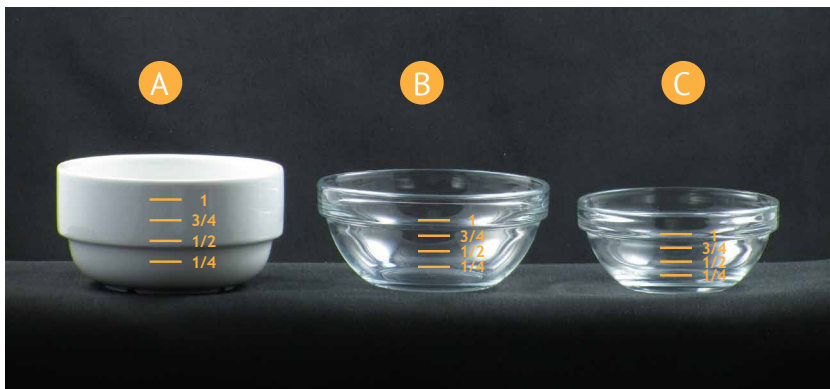

III. Quantidades

Tabela 1. Peso total

Código da série	Nome da série	Peso total (g)							
		A	B	C	D	E	F	G	H
MQA001	Espinafres, folhas verdes, cozidos	24	55	92	150	220	314		
MQA002	Couve, folhas verdes, cozida	21	41	79	116	191	272		
MQA003	Couve-flor, cozida	19	45	80	128	189	265		
MQA004	Alho-francês, cozido	17	34	66	99	146	207		
MQA005	Agrião, folhas verdes, cru	4	9	15	24	36	50		
MQA006	Feijão-verde, vagem, cozido	17	34	63	102	147	209		
MQA007	Curgete, rodela, cozida	23	48	91	145	213	299		
MQA008	Cenoura, rodela, cozida	22	46	81	129	191	269		
MQA011	Cenoura, ralada, crua	15	31	55	88	130	184		
MQA009	Pimento, cozido	17	38	68	110	162	227		
MQA010	Tomate, rodela, cru	18	38	67	110	163	232		
MQA012	Brócolos, cozidos	24	55	99	158	235	335		
MQA013	Couve-de-bruxelas, cozidas	20	43	77	125	186	259		
MQA015	Beringela, rodela, no forno	23	47	82	127	192	271		
MQA016	Pepino, rodela, cru	14	30	52	83	123	176		
MQA018	Salada verde	5	8	17	30	48	71		
MQA019	Salada verde, mista	21	50	90	143	217	311		
MQA149	Salada de couve-roxa, crua	25	52	92	146	219	311		
MQA024	Purê de vegetais, esparregado	17	34	71	126	200	298	419	
MQA109	Gratinado de vegetais	50	106	190	300	446	626		
MQA025	Leguminosas, feijão, cozido	38	79	140	223	334	467		
MQA017	Ervilhas, cozidas	16	34	60	96	142	200		
MQA161	Macedónia, cozida	19	41	77	103	186	276		
MQA034	Tremoços, prato de sobremesa	16	34	60	96	142	200		
MQA035	Tremoços, taça	16	34	60	96	142	200		
MQA020	Sopa, prato	46	60	169	269	399			
MQA021	Sopa, tijela	46	96	169	269	399			
MQA031	Azeitonas, prato de sobremesa	14	142	50	80	119	167		
MQA032	Azeitonas, taça	14	200	50	80	119	167		
MQA036	Salada de fruta, taça	59	124	215	355				
MQA037A	Morangos, taça	32	68	120	191	284	399		
MQA037B	Morangos, prato de sobremesa	32	68	120	191	284	399		
MQA038A	Uvas, prato de sobremesa	33	69	116	186	276	397		
MQA038B	Uvas, taça	33	69	116	186	276	397		
MQA039	Cerejas, prato de sobremesa	36	67	120	190	285	401		
MQA039B	Cerejas, taça	36	67	120	190	285			
MQA040	Melão	42	106	178	286	420	591		
MQA042	Meloa	56	105	186	274	379	484		
MQA043	Melancia	35	110	186	265	407	627		
MQA044	Manga	32	72	123	198	286	400		
MQA045	Ananás	26	46	84	135	200	284		
MQA065	Papa de fruta, prato	57	119	210	335	498			

Código da série	Nome da série	Peso total (g)							
		A	B	C	D	E	F	G	H
MQA065B	Papa de fruta, taça	57	119	210	335	498			
MQA046A	Frutos gordos s/casca, nozes, prato de sobremesa	14	28	50	80	119	167		
MQA046B	Frutos gordos s/casca, nozes, taça	14	28	50	80	119			
MQA046C	Frutos gordos c/casca, amendoim, prato de sobremesa	13	29	51	79	119	168		
MQA046D	Frutos gordos c/casca, amendoim, taça	13	29	51	79				
MQA046E	Frutos gordos s/casca, amendoim, prato de sobremesa	14	28	50	80	119	168		
MQA046F	Frutos gordos s/casca, amendoim, taça	14	28	50	80	119	168		
MQA046G	Frutos gordos c/casca, pistácio, prato de sobremesa	14	28	50	81	119	168		
MQA046H	Frutos gordos c/casca, pistácio, taça	14	28	50	81	119	168		
MQA047	Castanhas	27	56	102	161	237	334		
MQA056	Cereais, cornflakes, taça	8	17	30	48	71			
MQA055	Cereais, cornflakes, prato	8	17	30	48	71			
MQA057	Cereais, "fitness", special K, taça	8	17	30	48	71			
MQA058	Cereais, "fitness", special K, prato	8	17	30	48	71			
MQA059A	Cereais, muesli, taça	12	25	45	71	107			
MQA059B	Cereais, muesli, prato	12	25	45	72	107			
MQA060	Cereais, "chocapic", taça	8	17	30	48	71	120		
MQA061	Cereais, "chocapic", prato	8	17	30	48	71	120		
MQA062	Pão, fatias	42	71	59	115	53	91	58	97
MQA062B	Pão, inteiro	41	51	70	55	40	60		
MQA062C	Broa, de milho, de Avintes, pedaços	54	23	73					
MQA063A	Farinha láctea, "cerelac", prato	58	119	210	335	498			
MQA063B	Farinha Láctea, "cerelac", taça	58	119	210	335	498			
MQA064	Nestum, prato	54	81	169	300	479			
MQA069	Batata, pedaços, cozida	35	92	155	247	358	532		
MQA112	Salada russa	55	114	202	322	479	674		
MQA070	Batata frita, palitos	22	44	77	125	185	261		
MQA071	Batata frita, pacote	8	18	30	48	71	99		
MQA154	Puré de batata	52	148	240	331	478	674		
MQA072	Massa, cozida	26	53	94	151	224	317		
MQA073	Esparguete, cozido	32	65	116	185	275	387		
MQA076	Massa chinesa, cozida	59	124	220	350	520	734		
MQA148	Massa, com vegetais	41	88	156	246	366	512		
MQA077	Arroz branco, cozido	38	81	143	227	337	474		
MQA078	Arroz de ervilhas	36	75	132	211	313	441		
MQA080	Arroz malandro	53	110	195	313	465	654		
MQA145	Migas, c/ grelos	25	46	97	203	360	575		
MQA084	Açorda alentejana, tipo migas	46	95	169	269	399	563		
MQA052	Presunto, fatias	11	22	40	64	95			
MQA053	Fiambre, fatias	10	23	39	65	97			
MQA054	Chouriço, linguiça, rodelas	9	18	30	48	70	98		
MQA085	Bife	35	65	114	189	274	384		

Código da série	Nome da série	Peso total (g)							
		A	B	C	D	E	F	G	H
MQA087	Carne, pedaços, cozida	31	67	120	192	284	400		
MQA088	Carne, com ervilhas e cenouras, estufada	50	108	189	304	437	618		
MQA104	Jardineira, batata e carne estufada	59	129	226	358	528	734		
MQA105	Chili	39	82	146	233	346	487		
MQA086	Costeleta, com osso, grelhada	15	28	34	66	103	232		
MQA159	Entremeada	11	21	48	99	147	219	319	
MQA162	Entrecosto	52	109	199	317	468	667		
MQA155	Espetadas mistas, c/ espeto	52	87	173	269	361			
MQA155B	Espetadas mistas, s/ espeto	50	89	179	273	358			
MQA089	Carne, fatias, assada	22	49	103	155	208	321		
MQA163	Rolo de Carne	28	79	126	208	293	419		
MQA157	Panados de carne	21	53	97	191	287	400		
MQA091	Rojões	34	68	120	192	284	402		
MQA102	Bifanas	32	68	120	193	284	401		
MQA100	Tripas à moda do Porto	87	187	324	516	765	881		
MQA110	Feijoada de carnes	87	182	323	516	765	1078		
MQA103	Carne de porco à Alentejana	61	123	219	349	521	742		
MQA106	Strogonoff de carne	51	108	186	297	442	657		
MQA107	Carne, com batatas, estufada	60	126	223	356	528	744		
MQA090	Frango, assado	41	85	150	240	360	500		
MQA099	Frango estufado, c/ molho	64	157	265	383	598	837		
MQA101B	Moelas, c/ molho	33	68	121	192	284	401		
MQA111	Cozido à Portuguesa	103	216	386	607	822			
MQA144	Migas, à alentejana	97	203	360	575	853	1202		
MQA093	Rancho	82	175	310	492	740			
MQA153	Massa com carne ou peixe	86	153	245	366	587	872		
MQA097	Empadão de carne	86	195	315	551	789			
MQA074	Esparguete, bolonhesa	61	133	228	361	540	757		
MQA075	Esparguete, carbonara	59	124	220	351	521	734		
MQA081	Lasanha	66	149	243	398	570	847		
MQA082	Ravioli	38	68	141	247	398	598		
MQA113	Peixe, filete	32	56	87	142	227			
MQA114	Peixe, postas finas	36	78	134	220	311	453		
MQA115	Peixe, postas grossas	58	152	213	303				
MQA121	Peixes pequenos, fritos	29	57	100	162	239	332		
MQA122	Peixe, inteiro, grelhado	167	231	295					
MQA126	Caldeirada de peixe	99	208	368	587	872	1228		
MQA116	Bacalhau com cebolada	79	122	135	199	205	401		
MQA117	Bacalhau com grão de bico	66	137	243	388	576	811		
MQA118	Bacalhau com natas	90	136	242	388	590	901		
MQA119	Bacalhau espiritual	71	115	220	395	609	952		
MQA120	Bacalhau à Gomes de Sá	68	99	215	366	576	865		
MQA156	Pataniscas	29	62	102	159	236	340		
MQA098	Bacalhau, à Brás	41	68	141	250	399	593		
MQA092	Roupa velha	60	120	213	340	504			
MQA123	Mexilhão, s/ concha	11	23	40	64	95	134		

Código da série	Nome da série	Peso total (g)							
		A	B	C	D	E	F	G	H
MQA123B	Mexilhão, s/ concha, c/ molho	11	23	40	64	95	134		
MQA123C	Mexilhão, c/ concha	38	78	136	224	334	415		
MQA123D	Mexilhão, c/ concha, c/molho	33	66	115	189	281	351		
MQA124	Camarão	11	23	40	62	95	137	226	
MQA108	Chop suey	39	81	145	234	346	484		
MQA125	Calamares	26	53	88	151	208	300		
MQA129	Lulas, grelhadas	27	56	100	160	237	334		
MQA127	Lulas estufadas, com legumes	41	86	150	239	359	502		
MQA128	Polvo, cozido	27	56	98	160	238	334		
MQA079	Arroz de polvo	89	189	332	528	785			
MQA152	Arroz de peixe	54	103	261	401	699	1069		
MQA146	Tortilha	82	173	308	499	745	996		
MQA147A	Ovos mexidos	27	57	100	160	237	336		
MQA026	Queijo fresco, feta, tofu, fatias	15	26	49	85	130			
MQA027	Queijo fresco, inteiro	40	80	200					
MQA028	Requeijão, inteiro	50	100	200					
MQA029	Queijo saloio	29	48	55	94	109	188		
MQA048	Queijo brie, queijo camembert	12	22	40	62	93			
MQA049	Queijo da ilha, queijo manchego	13	21	40	64	96	143		
MQA050	Queijo chèvre, rolo, fatias	8	17	29	39	63	93		
MQA051	Queijo flamengo, fatias	11	23	39	64	96			
MQA066	Manteiga	3	5	10	15	20			
MQA067	Manteiga, em pão	3	5	10	15	20			
MQA068A	Doce, Compota, pão	5	11	20	32	47			
MQA068B	Doce, Compota, prato	5	11	20	32	47			
MQA130	Bolo leve, pão de ló	15	33	45	82	130	182		
MQA131	Bolo denso, de ananás	25	56	92	142	202	272		
MQA132	Bolo rei	28	41	92	139	205	290		
MQA140	Bolo de bolacha	26	48	70	106	156	260		
MQA133	Tarte fina	24	47	84	130	185	280		
MQA134	Tarte alta, c/ fruta	51	88	131	182	238	303		
MQA135	Torta, fatias redondas	24	46	83	126	190	260		
MQA136	Gelado, "viennetta", fatias	22	48	71	122	187			
MQA137	Pudim	54	84	133	206	288	418		
MQA138	Leite creme	38	77	134	218	319	451		
MQA139	Mousse, prato	8	16	35	64	128	256		
MQA139B	Mousse, taça	8	16	35	64	128	256		
MQA141	Aletria, prato	42	77	146	303	457	616		
MQA142	Aletria, prato de sobremesa	42	79	143	229	342			
MQA143	Pipocas	5	9	20	35	56	83		
MQA094	Quiche	33	69	126	206	329	489		
MQA095	Bola de carne, fatias	22	53	94	149	244	353		
MQA096	Tarte salgada, empada	39	60	99	182	255	356	563	
MQA151	Calzone	86	190	307	395				
MQA150A	Pizza grande	95	190	285	380	760			
MQA150B	Pizza média	54	108	216	324	432			

Tabela 2. Peso edível

Código da série	Nome da série	Peso edível (g)							
		A	B	C	D	E	F	G	H
MQA001	Espinafres, folhas verdes, cozidos	24	55	92	150	220	314		
MQA002	Couve, folhas verdes, cozida	21	41	79	116	191	272		
MQA003	Couve-flor, cozida	19	45	80	128	189	265		
MQA004	Alho-francês, cozido	17	34	66	99	146	207		
MQA005	Agrião, folhas verdes, cru	4	9	15	24	36	50		
MQA006	Feijão-verde, vagem, cozido	17	34	63	102	147	209		
MQA007	Curgete, rodela, cozida	23	48	91	145	213	299		
MQA008	Cenoura, rodela, cozida	22	46	81	129	191	269		
MQA011	Cenoura, ralada, crua	15	31	55	88	130	184		
MQA009	Pimento, cozido	17	38	68	110	162	227		
MQA010	Tomate, rodela, cru	18	38	67	110	163	232		
MQA012	Brócolos, cozidos	24	55	99	158	235	335		
MQA013	Couve-de-bruxelas, cozidas	20	43	77	125	186	259		
MQA015	Beringela, rodela, no forno	23	47	82	127	192	271		
MQA016	Pepino, rodela, cru	14	30	52	83	123	176		
MQA018	Salada verde	5	8	17	30	48	71		
MQA019	Salada verde, mista	21	50	90	143	217	311		
MQA149	Salada de couve-roxa, crua	25	52	92	146	219	311		
MQA024	Purê de vegetais, esparregado	17	34	71	126	200	298	419	
MQA109	Gratinado de vegetais	50	106	190	300	446	626		
MQA025	Leguminosas, feijão, cozido	38	79	140	223	334	467		
MQA017	Ervilhas, cozidas	16	34	60	96	142	200		
MQA161	Macedónia, cozida	19	41	77	103	186	276		
MQA034	Tremoços, prato de sobremesa	13	27	48	77	114	160		
MQA035	Tremoços, taça	13	27	48	77	114	160		
MQA020	Sopa, prato	46	95	169	269	399			
MQA021	Sopa, tijela	46	95	169	269	399			
MQA031	Azeitonas, prato de sobremesa	10	20	36	58	86	120		
MQA032	Azeitonas, taça	10	20	36	58	86	120		
MQA036	Salada de fruta, taça	59	124	215	355				
MQA037A	Morangos, taça	32	68	120	191	284	399		
MQA037B	Morangos, prato de sobremesa	32	68	120	191	284	399		
MQA038A	Uvas, prato de sobremesa	33	69	116	186	276	397		
MQA038B	Uvas, taça	33	69	116	186	276	397		
MQA039	Cerejas, prato de sobremesa	30	56	101	160	239	337		
MQA039B	Cerejas, taça	30	56	101	160	239			
MQA040	Melão	22	56	94	152	223	313		
MQA042	Meloa	33	62	110	162	224	286		
MQA043	Melancia	18	57	97	138	212	326		
MQA044	Manga	32	72	123	198	286	400		
MQA045	Ananás	26	46	84	135	200	284		
MQA065	Papa de fruta, prato	57	119	210	335	498			
MQA065B	Papa de fruta, taça	57	119	210	335	498			

Código da série	Nome da série	Peso edível (g)							
		A	B	C	D	E	F	G	H
MQA046A	Frutos gordos s/casca, nozes, prato de sobremesa	14	28	50	80	119	167		
MQA046B	Frutos gordos s/casca, nozes, taça	14	28	50	80	119			
MQA046C	Frutos gordos c/casca, amendoim, prato de sobremesa	9	20	36	55	83	118		
MQA046D	Frutos gordos c/casca, amendoim, taça	9	20	36	55				
MQA046E	Frutos gordos s/casca, amendoim, prato de sobremesa	14	28	50	80	119	168		
MQA046F	Frutos gordos s/casca, amendoim, taça	14	28	50	80	119	168		
MQA046G	Frutos gordos c/casca, pistácio, prato de sobremesa	8	15	28	45	65	92		
MQA046H	Frutos gordos c/casca, pistácio, taça	8	15	28	45	65	92		
MQA047	Castanhas	25	51	93	147	216	304		
MQA056	Cereais, cornflakes, taça	8	17	30	48	71			
MQA055	Cereais, cornflakes, prato	8	17	30	48	71			
MQA057	Cereais, "fitness", special K, taça	8	17	30	48	71			
MQA058	Cereais, "fitness", special K, prato	8	17	30	48	71			
MQA059A	Cereais, muesli, taça	12	25	45	71	107			
MQA059B	Cereais, muesli, prato	12	25	45	72	107			
MQA060	Cereais, "chocapic", taça	8	17	30	48	71	120		
MQA061	Cereais, "chocapic", prato	8	17	30	48	71	120		
MQA062	Pão, fatias	42	71	59	115	53	91	58	97
MQA062B	Pão, inteiro	41	51	70	55	40	60		
MQA062C	Broa, de milho, de Avintes, pedaços	54	23	73					
MQA063A	Farinha láctea, "cerelac", prato	58	119	210	335	498			
MQA063B	Farinha Láctea, "cerelac", taça	58	119	210	335	498			
MQA064	Nestum, prato	54	81	169	300	479			
MQA069	Batata, pedaços, cozida	35	92	155	247	358	532		
MQA112	Salada russa	55	114	202	322	479	674		
MQA070	Batata frita, palitos	22	44	77	125	185	261		
MQA071	Batata frita, pacote	8	18	30	48	71	99		
MQA154	Puré de batata	52	148	240	331	478	674		
MQA072	Massa, cozida	26	53	94	151	224	317		
MQA073	Esparguete, cozido	32	65	116	185	275	387		
MQA076	Massa chinesa, cozida	59	124	220	350	520	734		
MQA148	Massa, com vegetais	41	88	156	246	366	512		
MQA077	Arroz branco, cozido	38	81	143	227	337	474		
MQA078	Arroz de ervilhas	36	75	132	211	313	441		
MQA080	Arroz malandro	53	110	195	313	465	654		
MQA145	Migas, c/ grelos	25	46	97	203	360	575		
MQA084	Açorda alentejana, tipo migas	46	95	169	269	399	563		
MQA052	Presunto, fatias	11	22	40	64	95			
MQA053	Fiambre, fatias	10	23	39	65	97			
MQA054	Chouriço, linguiça, rodelas	9	18	30	48	70	98		
MQA085	Bife	35	65	114	189	274	384		
MQA087	Carne, pedaços, cozida	31	67	120	192	284	400		

Código da série	Nome da série	Peso edível (g)							
		A	B	C	D	E	F	G	H
MQA088	Carne, com ervilhas e cenouras, estufada	50	108	189	304	437	618		
MQA104	Jardineira, batata e carne estufada	59	129	226	358	528	734		
MQA105	Chili	39	82	146	233	346	487		
MQA086	Costeleta, com osso, grelhada	11	21	25	48	75	170		
MQA159	Entremeada	10	20	45	92	137	204	297	
MQA162	Entrecosto	28	58	106	168	249	355		
MQA155	Espetadas mistas, c/ espeto	50	89	179	273	358			
MQA155B	Espetadas mistas, s/ espeto	50	89	179	273	358			
MQA089	Carne, fatias, assada	22	49	103	155	208	321		
MQA163	Rolo de Carne	28	79	126	208	293	419		
MQA157	Panados de carne	21	53	97	191	287	400		
MQA091	Rojões	34	68	120	192	284	402		
MQA102	Bifanas	32	68	120	193	284	401		
MQA100	Tripas à moda do Porto	87	187	324	516	765	881		
MQA110	Feijoada de carnes	87	182	323	516	765	1078		
MQA103	Carne de porco à Alentejana	35	71	127	203	302	431		
MQA106	Strogonoff de carne	51	108	186	297	442	657		
MQA107	Carne, com batatas, estufada	60	126	223	356	528	744		
MQA090	Frango, assado	23	48	85	136	203	282		
MQA099	Frango estufado, c/ molho	47	114	193	279	435	609		
MQA101B	Moelas, c/ molho	33	68	121	192	284	401		
MQA111	Cozido à Portuguesa	87	183	327	514	696			
MQA144	Migas, à alentejana	90	189	334	534	792	1117		
MQA093	Rancho	82	175	310	492	740			
MQA153	Massa com carne ou peixe	86	153	245	366	587	872		
MQA097	Empadão de carne	86	195	315	551	789			
MQA074	Esparguete, bolonhesa	61	133	228	361	540	757		
MQA075	Esparguete, carbonara	59	124	220	351	521	734		
MQA081	Lasanha	66	149	243	398	570	847		
MQA082	Ravioli	38	68	141	247	398	598		
MQA113	Peixe, filete	32	56	87	142	227			
MQA114	Peixe, postas finas	25	54	92	151	214	311		
MQA115	Peixe, postas grossas	42	110	153	218				
MQA121	Peixes pequenos, fritos	16	31	55	89	131	182		
MQA122	Peixe, inteiro, grelhado	80	110	141					
MQA126	Caldeirada de peixe	99	208	368	587	872	1228		
MQA116	Bacalhau com cebolada	67	103	114	168	173	338		
MQA117	Bacalhau com grão de bico	66	137	243	388	576	811		
MQA118	Bacalhau com natas	90	136	242	388	590	901		
MQA119	Bacalhau espiritual	71	115	220	395	609	952		
MQA120	Bacalhau à Gomes de Sá	68	99	215	366	576	865		
MQA156	Pataniscas	29	62	102	159	236	340		
MQA098	Bacalhau, à Brás	41	68	141	250	399	593		
MQA092	Roupa velha	52	103	184	293	435			
MQA123	Mexilhão, s/ concha	11	23	40	64	95	134		
MQA123B	Mexilhão, s/ concha, c/ molho	11	23	40	64	95	134		

Código da série	Nome da série	Peso edível (g)							
		A	B	C	D	E	F	G	H
MQA123C	Mexilhão, c/ concha	7	15	26	44	65	81		
MQA123D	Mexilhão, c/ concha, c/molho	8	16	27	44	66	83		
MQA124	Camarão	6	12	20	31	48	69	113	
MQA108	Chop suey	39	81	145	234	346	484		
MQA125	Calamares	26	53	88	151	208	300		
MQA129	Lulas, grelhadas	27	56	100	160	237	334		
MQA127	Lulas estufadas, com legumes	41	86	150	239	359	502		
MQA128	Polvo, cozido	27	56	98	160	238	334		
MQA079	Arroz de polvo	89	189	332	528	785			
MQA152	Arroz de peixe	54	103	261	401	699	1069		
MQA146	Tortilha	82	173	308	499	745	996		
MQA147A	Ovos mexidos	27	57	100	160	237	336		
MQA026	Queijo fresco, feta, tofu, fatias	15	26	49	85	130			
MQA027	Queijo fresco, inteiro	40	80	200					
MQA028	Requeijão, inteiro	50	100	200					
MQA029	Queijo saloio	29	48	55	94	109	188		
MQA048	Queijo brie, queijo camembert	12	22	40	62	93			
MQA049	Queijo da ilha, queijo manchego	13	21	40	64	96	143		
MQA050	Queijo chèvre, rolo, fatias	8	17	29	39	63	93		
MQA051	Queijo flamengo, fatias	11	23	39	64	96			
MQA066	Manteiga	3	5	10	15	20			
MQA067	Manteiga, em pão	3	5	10	15	20			
MQA068A	Doce, Compota, pão	5	11	20	32	47			
MQA068B	Doce, Compota, prato	5	11	20	32	47			
MQA130	Bolo leve, pão de ló	15	33	45	82	130	182		
MQA131	Bolo denso, de ananás	25	56	92	142	202	272		
MQA132	Bolo rei	28	41	92	139	205	290		
MQA140	Bolo de bolacha	26	48	70	106	156	260		
MQA133	Tarte fina	24	47	84	130	185	280		
MQA134	Tarte alta, c/ fruta	51	88	131	182	238	303		
MQA135	Torta, fatias redondas	24	46	83	126	190	260		
MQA136	Gelado, "viennetta", fatias	22	48	71	122	187			
MQA137	Pudim	54	84	133	206	288	418		
MQA138	Leite creme	38	77	134	218	319	451		
MQA139	Mousse, prato	8	16	35	64	128	256		
MQA139B	Mousse, taça	8	16	35	64	128	256		
MQA141	Aletria, prato	42	77	146	303	457	616		
MQA142	Aletria, prato de sobremesa	42	79	143	229	342			
MQA143	Pipocas	5	9	20	35	56	83		
MQA094	Quiche	33	69	126	206	329	489		
MQA095	Bola de carne, fatias	22	53	94	149	244	353		
MQA096	Tarte salgada, empada	39	60	99	182	255	356	563	
MQA151	Calzone	86	190	307	395				
MQA150A	Pizza grande	95	190	285	380	760			
MQA150B	Pizza média	54	108	216	324	432			

Tabela 3. Composição Nutricional

Código e nome da série		Energia (kcal)	Proteína (g)	Hidratos de carbono (g)	Açúcares (g)	Gordura (g)	Ácidos gordos saturados (g)	Fibra (g)
MQA001 Espinafres, folhas verdes, cozidos	A	7	0,6	0,2	0,2	0,2	0,0	0,6
	B	16	1,4	0,4	0,4	0,5	0,1	1,4
	C	26	2,3	0,7	0,6	0,8	0,1	2,4
	D	43	3,7	1,1	1,0	1,3	0,1	3,8
	E	63	5,5	1,7	1,5	1,9	0,2	5,6
	F	89	7,8	2,4	2,1	2,7	0,3	8,0
MQA002 Couve, folhas verdes, cozida	A	6	0,4	0,6	0,6	0,1	0,0	0,4
	B	12	0,8	1,2	1,2	0,1	0,0	0,9
	C	23	1,5	2,4	2,3	0,3	0,0	1,7
	D	34	2,2	3,5	3,4	0,4	0,0	2,5
	E	57	3,6	5,7	5,5	0,7	0,0	4,0
	F	80	5,1	8,1	7,9	0,9	0,0	5,8
MQA003 Couve-flor, cozida	A	6	0,6	0,6	0,5	0,0	0,0	0,3
	B	15	1,5	1,4	1,1	0,1	0,0	0,8
	C	27	2,7	2,4	2,0	0,1	0,0	1,4
	D	44	4,3	3,9	3,3	0,2	0,0	2,3
	E	64	6,4	5,7	4,8	0,3	0,0	3,4
	F	90	8,9	8,0	6,8	0,5	0,0	4,7
MQA004 Alho-francês, cozido	A	4	0,3	0,4	0,3	0,0	0,0	0,4
	B	9	0,5	0,9	0,7	0,1	0,0	0,8
	C	17	1,1	1,7	1,3	0,2	0,1	1,5
	D	26	1,6	2,6	2,0	0,3	0,1	2,2
	E	38	2,4	3,8	2,9	0,4	0,1	3,2
	F	54	3,3	5,4	4,1	0,6	0,2	4,6
MQA005 Agrião, folhas verdes, cru	A	1	0,1	0,0	0,0	0,0	0,0	0,1
	B	3	0,3	0,0	0,0	0,1	0,0	0,3
	C	4	0,5	0,1	0,1	0,1	0,0	0,4
	D	7	0,8	0,1	0,1	0,2	0,1	0,7
	E	11	1,2	0,1	0,1	0,3	0,1	1,1
	F	15	1,7	0,2	0,2	0,4	0,2	1,5
MQA006 Feijão-verde, vagem, cozido	A	5	0,3	0,6	0,4	0,0	0,0	0,5
	B	11	0,6	1,2	0,9	0,1	0,0	0,9
	C	20	1,1	2,2	1,6	0,2	0,1	1,8
	D	32	1,7	3,5	2,6	0,3	0,1	2,8
	E	46	2,5	5,0	3,7	0,4	0,1	4,1
	F	66	3,6	7,1	5,3	0,6	0,2	5,8
MQA007 Curgete, rodela, cozida	A	6	0,4	0,5	0,5	0,1	0,0	0,3
	B	12	0,9	1,1	1,0	0,2	0,1	0,6
	C	22	1,7	2,1	2,0	0,3	0,1	1,1
	D	35	2,7	3,3	3,2	0,5	0,2	1,7
	E	52	3,9	4,9	4,7	0,7	0,3	2,5
	F	73	5,5	6,9	6,5	1,0	0,4	3,6

Código e nome da série		Energia (kcal)	Proteína (g)	Hidratos de carbono (g)	Açúcares (g)	Gordura (g)	Ácidos gordos saturados (g)	Fibra (g)
MQA008 Cenoura, rodelas, cozida	A	6	0,1	0,9	0,9	0,0	0,0	0,6
	B	12	0,3	1,9	1,8	0,0	0,0	1,2
	C	22	0,5	3,4	3,2	0,0	0,0	2,1
	D	34	0,7	5,4	5,0	0,0	0,0	3,3
	E	51	1,1	8,0	7,5	0,0	0,0	4,9
	F	72	1,5	11,3	10,5	0,0	0,0	6,9
MQA011 Cenoura, ralada, crua	A	4	0,1	0,7	0,6	0,0	0,0	0,4
	B	8	0,2	1,4	1,3	0,0	0,0	0,8
	C	14	0,3	2,4	2,3	0,0	0,0	1,4
	D	22	0,5	3,9	3,6	0,0	0,0	2,3
	E	33	0,8	5,7	5,3	0,0	0,0	3,4
	F	46	1,1	8,1	7,5	0,0	0,0	4,8
MQA009 Pimento, cozido	A	5	0,2	0,4	0,4	0,1	0,0	0,3
	B	10	0,5	0,9	0,9	0,2	0,0	0,7
	C	18	1,0	1,6	1,5	0,4	0,1	1,3
	D	29	1,6	2,7	2,5	0,6	0,1	2,0
	E	43	2,3	3,9	3,6	0,9	0,2	3,0
	F	60	3,3	5,5	5,1	1,2	0,2	4,2
MQA010 Tomate, rodelas, cru	A	4	0,1	0,6	0,6	0,1	0,0	0,2
	B	9	0,3	1,3	1,3	0,1	0,0	0,5
	C	15	0,5	2,3	2,3	0,2	0,0	0,9
	D	25	0,9	3,8	3,8	0,3	0,0	1,4
	E	37	1,3	5,7	5,7	0,5	0,0	2,1
	F	52	1,9	8,1	8,1	0,7	0,0	3,0
MQA012 Brócolos, cozidos	A	7	0,7	0,3	0,2	0,2	0,0	0,5
	B	16	1,5	0,7	0,5	0,4	0,0	1,2
	C	29	2,7	1,2	1,0	0,6	0,1	2,2
	D	46	4,4	1,9	1,5	1,0	0,1	3,5
	E	68	6,5	2,9	2,3	1,5	0,2	5,1
	F	97	9,3	4,1	3,3	2,2	0,3	7,3
MQA013 Couve-de-bruxelas, cozidas	A	10	0,6	0,7	0,6	0,3	0,1	0,7
	B	21	1,3	1,5	1,2	0,5	0,1	1,5
	C	38	2,4	2,8	2,1	1,0	0,2	2,7
	D	62	3,9	4,5	3,5	1,6	0,3	4,4
	E	93	5,8	6,7	5,2	2,3	0,5	6,5
	F	129	8,1	9,3	7,2	3,3	0,7	9,1
MQA015 Beringela, rodelas, no forno	A	6	0,3	0,7	0,7	0,1	0,0	0,8
	B	13	0,7	1,5	1,4	0,1	0,0	1,5
	C	23	1,2	2,6	2,4	0,2	0,0	2,7
	D	36	1,8	4,0	3,7	0,3	0,0	4,2
	E	54	2,8	6,0	5,5	0,5	0,1	6,3
	F	76	3,9	8,5	7,8	0,7	0,1	8,9

Código e nome da série		Energia (kcal)	Proteína (g)	Hidratos de carbono (g)	Açúcares (g)	Gordura (g)	Ácidos gordos saturados (g)	Fibra (g)
MQA016 Pepino, rodela, cru	A	3	0,2	0,2	0,2	0,1	0,0	0,1
	B	6	0,4	0,5	0,5	0,2	0,1	0,2
	C	10	0,7	0,9	0,8	0,3	0,1	0,4
	D	16	1,2	1,4	1,3	0,5	0,2	0,6
	E	24	1,7	2,1	2,0	0,7	0,2	0,9
	F	34	2,5	3,0	2,8	1,1	0,4	1,2
MQA018 Salada verde	A	1	0,1	0,0	0,0	0,0	0,0	0,1
	B	2	0,2	0,0	0,0	0,0	0,0	0,1
	C	3	0,5	0,1	0,1	0,1	0,0	0,3
	D	6	0,8	0,1	0,1	0,1	0,0	0,5
	E	9	1,3	0,2	0,2	0,2	0,0	0,8
	F	14	1,9	0,3	0,3	0,2	0,0	1,2
MQA019 Salada verde, mista	A	10	0,2	0,5	0,5	0,7	0,1	0,3
	B	24	0,5	1,2	1,2	1,7	0,2	0,6
	C	43	1,0	2,2	2,2	3,1	0,4	1,1
	D	68	1,5	3,5	3,5	4,9	0,7	1,8
	E	103	2,3	5,4	5,4	7,4	1,0	2,7
	F	148	3,4	7,7	7,7	10,6	1,4	3,8
MQA149 Salada de couve-roxa, crua	A	23	0,4	1,5	1,4	1,5	0,2	0,6
	B	48	0,9	3,2	3,0	3,2	0,5	1,2
	C	86	1,6	5,6	5,3	5,7	0,9	2,1
	D	136	2,5	8,9	8,3	9,0	1,4	3,4
	E	204	3,7	13,3	12,5	13,6	2,0	5,1
	F	290	5,3	18,9	17,8	19,3	2,9	7,3
MQA024 Puré de vegetais, esparregado	A	14	0,5	1,4	0,5	0,6	0,3	0,3
	B	28	1,0	2,7	1,0	1,2	0,7	0,5
	C	58	2,1	5,7	2,1	2,6	1,4	1,1
	D	102	3,7	10,1	3,7	4,5	2,4	2,0
	E	162	5,8	16,1	5,8	7,2	3,9	3,2
	F	242	8,7	24,0	8,7	10,7	5,8	4,8
	G	340	12,2	33,7	12,2	15,1	8,1	6,7
MQA109 Gratinado de vegetais	A	19	1,0	1,0	0,6	1,2	0,6	0,2
	B	41	2,0	2,2	1,3	2,5	1,3	0,5
	C	73	3,7	3,9	2,4	4,5	2,3	0,9
	D	115	5,8	6,2	3,8	7,0	3,6	1,4
	E	171	8,6	9,2	5,7	10,5	5,4	2,0
	F	240	12,1	12,9	8,0	14,7	7,6	2,8
MQA025 Leguminosas, feijão, cozido	A	47	3,5	6,7	0,2	0,2	0,0	1,1
	B	97	7,3	14,0	0,5	0,5	0,1	2,3
	C	173	12,9	24,9	0,9	0,8	0,1	4,0
	D	275	20,5	39,6	1,4	1,3	0,2	6,4
	E	412	30,7	59,3	2,2	2,0	0,3	9,6
	F	576	42,9	82,9	3,0	2,8	0,4	13,5

Código e nome da série		Energia (kcal)	Proteína (g)	Hidratos de carbono (g)	Açúcares (g)	Gordura (g)	Ácidos gordos saturados (g)	Fibra (g)
MQA017 Ervilhas, cozidas	A	12	1,0	1,3	0,3	0,1	0,0	0,8
	B	25	2,1	2,7	0,5	0,2	0,0	1,6
	C	43	3,7	4,7	1,0	0,4	0,1	2,9
	D	69	6,0	7,6	1,5	0,7	0,1	4,6
	E	103	8,8	11,2	2,3	1,0	0,1	6,8
	F	145	12,4	15,8	3,2	1,4	0,2	9,6
MQA161 Macedónia, cozida	A	17	1,2	1,7	0,6	0,1	0,0	1,3
	B	37	2,7	3,6	1,3	0,2	0,0	2,9
	C	69	5,0	6,8	2,5	0,5	0,1	5,4
	D	92	6,7	9,1	3,3	0,6	0,1	7,2
	E	166	12,1	16,5	6,0	1,1	0,2	13,0
	F	247	18,0	24,4	8,9	1,7	0,3	19,4
MQA034 Tremoços, prato de sobremesa	A	16	2,1	0,9	0,1	0,3	0	0,6
	B	34	4,5	2	0,1	0,7	0,1	1,3
	C	60	7,9	3,5	0,2	1,2	0,1	2,3
	D	96	12,6	5,5	0,4	1,8	0,2	3,7
	E	143	18,6	8,2	0,6	2,7	0,3	5,5
	F	201	26,2	11,5	0,8	3,8	0,5	7,7
MQA035 Tremoços, taça	A	16	2,1	0,9	0,1	0,3	0	0,6
	B	34	4,5	2	0,1	0,7	0,1	1,3
	C	60	7,9	3,5	0,2	1,2	0,1	2,3
	D	96	12,6	5,5	0,4	1,8	0,2	3,7
	E	143	18,6	8,2	0,6	2,7	0,3	5,5
	F	201	26,2	11,5	0,8	3,8	0,5	7,7
MQA020 Sopa, prato	A	26	0,8	3,4	1,0	0,9	0,1	0,7
	B	55	1,7	7,0	2,0	1,9	0,3	1,5
	C	97	3,1	12,4	3,6	3,3	0,5	2,7
	D	155	4,9	19,7	5,7	5,3	0,8	4,3
	E	230	7,3	29,3	8,5	7,8	1,2	6,4
MQA021 Sopa, tijela	A	26	0,8	3,4	1,0	0,9	0,1	0,7
	B	55	1,7	7,0	2,0	1,9	0,3	1,5
	C	97	3,1	12,4	3,6	3,3	0,5	2,7
	D	155	4,9	19,7	5,7	5,3	0,8	4,3
	E	230	7,3	29,3	8,5	7,8	1,2	6,4
MQA031 Azeitonas, prato de sobremesa	A	18	0,1	0,0	0,0	1,9	0,3	0,4
	B	36	0,3	0,0	0,0	3,7	0,6	0,8
	C	65	0,5	0,0	0,0	6,7	1,0	1,4
	D	104	0,8	0,0	0,0	10,7	1,7	2,3
	E	154	1,2	0,0	0,0	15,9	2,5	3,4
	F	217	1,7	0,0	0,0	22,2	3,5	4,8

Código e nome da série		Energia (kcal)	Proteína (g)	Hidratos de carbono (g)	Açúcares (g)	Gordura (g)	Ácidos gordos saturados (g)	Fibra (g)
MQA032 Azeitonas, taça	A	18	0,1	0,0	0,0	1,9	0,3	0,4
	B	36	0,3	0,0	0,0	3,7	0,6	0,8
	C	65	0,5	0,0	0,0	6,7	1,0	1,4
	D	104	0,8	0,0	0,0	10,7	1,7	2,3
	E	154	1,2	0,0	0,0	15,9	2,5	3,4
	F	217	1,7	0,0	0,0	22,2	3,5	4,8
MQA036 Salada de fruta, taça	A	34	0,4	6,9	6,8	0,2	0,0	1,2
	B	72	0,9	14,5	14,2	0,4	0,1	2,6
	C	125	1,5	25,2	24,6	0,6	0,1	4,4
	D	206	2,5	41,6	40,7	1,1	0,1	7,3
MQA037A Morangos, taça	A	11	0,2	1,7	1,7	0,1	0,0	0,6
	B	23	0,4	3,6	3,6	0,3	0,0	1,4
	C	40	0,7	6,4	6,4	0,5	0,0	2,4
	D	64	1,1	10,1	10,1	0,8	0,0	3,8
	E	95	1,7	15,1	15,1	1,1	0,0	5,7
	F	134	2,4	21,1	21,1	1,6	0,0	8,0
MQA037B Morangos, prato de sobremesa	A	11	0,2	1,7	1,7	0,1	0,0	0,6
	B	23	0,4	3,6	3,6	0,3	0,0	1,4
	C	40	0,7	6,4	6,4	0,5	0,0	2,4
	D	64	1,1	10,1	10,1	0,8	0,0	3,8
	E	95	1,7	15,1	15,1	1,1	0,0	5,7
	F	134	2,4	21,1	21,1	1,6	0,0	8,0
MQA038A Uvas, prato de sobremesa	A	27	0,1	6,1	6,1	0,2	0,0	0,3
	B	57	0,2	12,8	12,8	0,3	0,1	0,6
	C	96	0,3	21,6	21,6	0,6	0,1	1,0
	D	155	0,6	34,6	34,6	0,9	0,2	1,7
	E	229	0,8	51,3	51,3	1,4	0,3	2,5
	F	330	1,2	73,8	73,8	2,0	0,4	3,6
MQA038B Uvas, taça	A	27	0,1	6,1	6,1	0,2	0,0	0,3
	B	57	0,2	12,8	12,8	0,3	0,1	0,6
	C	96	0,3	21,6	21,6	0,6	0,1	1,0
	D	155	0,6	34,6	34,6	0,9	0,2	1,7
	E	229	0,8	51,3	51,3	1,4	0,3	2,5
	F	330	1,2	73,8	73,8	2,0	0,4	3,6
MQA039 Cerejas, prato de sobremesa	A	20	0,2	4,0	4,0	0,2	0,1	0,5
	B	38	0,5	7,5	7,5	0,4	0,1	0,9
	C	68	0,8	13,4	13,4	0,7	0,2	1,6
	D	107	1,3	21,2	21,2	1,1	0,3	2,6
	E	160	1,9	31,8	31,8	1,7	0,5	3,8
	F	226	2,7	44,8	44,8	2,4	0,7	5,4

Código e nome da série		Energia (kcal)	Proteína (g)	Hidratos de carbono (g)	Açúcares (g)	Gordura (g)	Ácidos gordos saturados (g)	Fibra (g)
MQA039B Cerejas, taça	A	20	0,2	4,0	4,0	0,2	0,1	0,5
	B	38	0,5	7,5	7,5	0,4	0,1	0,9
	C	68	0,8	13,4	13,4	0,7	0,2	1,6
	D	107	1,3	21,2	21,2	1,1	0,3	2,6
	E	160	1,9	31,8	31,8	1,7	0,5	3,8
MQA040 Melão	A	7	0,1	1,3	1,3	0,1	0,0	0,2
	B	17	0,3	3,2	3,2	0,2	0,1	0,5
	C	28	0,6	5,4	5,4	0,3	0,1	0,8
	D	45	0,9	8,6	8,6	0,5	0,2	1,4
	E	66	1,3	12,7	12,7	0,7	0,2	2,0
	F	93	1,9	17,9	17,9	0,9	0,3	2,8
MQA042 Meloa	A	8	0,2	1,4	1,4	0,0	0,0	0,3
	B	14	0,4	2,6	2,6	0,1	0,0	0,6
	C	25	0,7	4,6	4,6	0,1	0,0	1,0
	D	37	1,0	6,8	6,8	0,2	0,0	1,5
	E	52	1,3	9,4	9,4	0,2	0,0	2,0
	F	66	1,7	12,0	12,0	0,3	0,0	2,6
MQA043 Melancia	A	5	0,1	1,0	1,0	0,0	0,0	0,1
	B	15	0,2	3,1	3,1	0,1	0,0	0,2
	C	25	0,4	5,3	5,3	0,2	0,0	0,3
	D	36	0,6	7,6	7,6	0,3	0,0	0,4
	E	55	0,8	11,6	11,6	0,4	0,0	0,6
	F	85	1,3	17,9	17,9	0,7	0,0	1,0
MQA044 Manga	A	19	0,2	3,7	3,7	0,1	0,0	0,9
	B	43	0,4	8,4	8,3	0,2	0,1	2,1
	C	73	0,6	14,4	14,1	0,4	0,1	3,6
	D	117	1,0	23,2	22,8	0,6	0,2	5,7
	E	169	1,4	33,5	32,9	0,9	0,3	8,3
	F	236	2,0	46,8	46,0	1,2	0,4	11,6
MQA045 Ananás	A	12	0,1	2,5	2,5	0,1	0,0	0,3
	B	22	0,2	4,4	4,4	0,1	0,0	0,6
	C	40	0,4	8,0	8,0	0,2	0,0	1,0
	D	64	0,7	12,8	12,8	0,3	0,0	1,6
	E	95	1,0	19,0	19,0	0,4	0,0	2,4
	F	135	1,4	27,0	27,0	0,6	0,0	3,4
MQA065 Papa de fruta, prato	A	32	0,1	5,3	5,3	0,3	0,0	1,0
	B	67	0,3	11,0	11,0	0,6	0,1	2,0
	C	118	0,5	19,3	19,3	1,0	0,1	3,5
	D	187	0,8	30,9	30,9	1,6	0,1	5,6
	E	279	1,2	45,9	45,9	2,3	0,2	8,4

Código e nome da série		Energia (kcal)	Proteína (g)	Hidratos de carbono (g)	Açúcares (g)	Gordura (g)	Ácidos gordos saturados (g)	Fibra (g)
MQA065B Papa de fruta, taça	A	32	0,1	5,3	5,3	0,3	0,0	1,0
	B	67	0,3	11,0	11,0	0,6	0,1	2,0
	C	118	0,5	19,3	19,3	1,0	0,1	3,5
	D	187	0,8	30,9	30,9	1,6	0,1	5,6
	E	279	1,2	45,9	45,9	2,3	0,2	8,4
MQA046A Frutos gordos s/casca, nozes, prato de sobremesa	A	98	2,3	0,5	0,4	9,4	0,8	0,7
	B	196	4,7	1,0	0,7	18,9	1,5	1,5
	C	350	8,3	1,8	1,3	33,8	2,7	2,6
	D	559	13,4	2,9	2,1	54,0	4,3	4,2
	E	832	19,9	4,3	3,1	80,3	6,4	6,2
	F	1167	27,9	6,0	4,3	112,7	9,0	8,7
MQA046B Frutos gordos s/casca, nozes, taça	A	98	2,3	0,5	0,4	9,4	0,8	0,7
	B	196	4,7	1,0	0,7	18,9	1,5	1,5
	C	350	8,3	1,8	1,3	33,8	2,7	2,6
	D	559	13,4	2,9	2,1	54,0	4,3	4,2
	E	832	19,9	4,3	3,1	80,3	6,4	6,2
MQA046C Frutos gordos c/casca, amendoim, prato de sobremesa	A	54	2,3	0,9	0,4	4,3	0,8	0,8
	B	120	5,2	2,1	1	9,7	1,7	1,8
	C	210	9,1	3,6	1,7	17	3	3,1
	D	326	14	5,6	2,7	26,4	4,7	4,9
	E	491	21,2	8,4	4	39,7	7,1	7,3
	F	693	29,9	11,9	5,6	56,1	10	10,3
MQA046D Frutos gordos c/casca, amendoim, taça	A	54	2,3	0,9	0,4	4,3	0,8	0,8
	B	120	5,2	2,1	1	9,7	1,7	1,8
	C	210	9,1	3,6	1,7	17	3	3,1
	D	326	14	5,6	2,7	26,4	4,7	4,9
MQA046E Frutos gordos s/casca, amendoim, prato de sobremesa	A	82	3,6	1,4	0,7	6,7	1,2	1,2
	B	165	7,1	2,8	1,3	13,4	2,4	2,5
	C	294	12,7	5,0	2,4	23,9	4,2	4,4
	D	471	20,3	8,1	3,8	38,2	6,8	7,0
	E	701	30,2	12,0	5,7	56,8	10,1	10,5
	F	989	42,7	17,0	8,1	80,1	14,3	14,8
MQA046F Frutos gordos s/casca, amendoim, taça	A	82	3,6	1,4	0,7	6,7	1,2	1,2
	B	165	7,1	2,8	1,3	13,4	2,4	2,5
	C	294	12,7	5,0	2,4	23,9	4,2	4,4
	D	471	20,3	8,1	3,8	38,2	6,8	7,0
	E	701	30,2	12,0	5,7	56,8	10,1	10,5
	F	989	42,7	17,0	8,1	80,1	14,3	14,8
MQA046G Frutos gordos c/casca, pistachio, prato de sobremesa	A	47	1,4	1	0,7	4,1	0,5	0,7
	B	95	2,8	1,9	1,4	8,2	1	1,3
	C	170	5	3,5	2,4	14,6	1,8	2,3
	D	275	8	5,6	3,9	23,6	3	3,8
	E	403	11,8	8,2	5,8	34,7	4,4	5,6
	F	570	16,6	11,6	8,1	49	6,2	7,9

Código e nome da série		Energia (kcal)	Proteína (g)	Hidratos de carbono (g)	Açúcares (g)	Gordura (g)	Ácidos gordos saturados (g)	Fibra (g)
MQA046H Frutos gordos c/casca, pistachio, taça	A	47	1.4	1	0.7	4.1	0.5	0.7
	B	95	2.8	1.9	1.4	8.2	1	1.3
	C	170	5	3.5	2.4	14.6	1.8	2.3
	D	275	8	5.6	3.9	23.6	3	3.8
	E	403	11.8	8.2	5.8	34.7	4.4	5.6
	F	570	16.6	11.6	8.1	49	6.2	7.9
MQA047 Castanhas	A	48	0,8	9,8	2,4	0,3	0,0	1,5
	B	99	1,6	20,3	5,0	0,6	0,1	3,1
	C	180	2,9	36,9	9,1	1,0	0,2	5,7
	D	284	4,5	58,3	14,4	1,6	0,3	8,9
	E	418	6,7	85,8	21,1	2,4	0,4	13,2
	F	589	9,4	121,0	29,8	3,3	0,6	18,5
MQA056 Cereais, corn-flakes, taça	A	30	0,6	6,5	0,5	0,1	0,0	0,3
	B	64	1,3	13,8	1,1	0,2	0,1	0,7
	C	112	2,4	24,3	1,9	0,3	0,1	1,2
	D	179	3,8	38,9	3,0	0,5	0,1	1,9
	E	265	5,6	57,6	4,4	0,8	0,2	2,8
MQA055 Cereais, corn-flakes, prato	A	30	0,6	6,5	0,5	0,1	0,0	0,3
	B	64	1,3	13,8	1,1	0,2	0,1	0,7
	C	112	2,4	24,3	1,9	0,3	0,1	1,2
	D	179	3,8	38,9	3,0	0,5	0,1	1,9
	E	265	5,6	57,6	4,4	0,8	0,2	2,8
MQA057 Cereais, “fitness”, special K, taça	A	31	0,5	6,7	1,3	0,1	0,0	0,6
	B	65	1,1	14,2	2,9	0,2	0,1	1,2
	C	115	1,9	25,1	5,0	0,3	0,1	2,1
	D	184	3,0	40,2	8,1	0,5	0,1	3,4
	E	272	4,5	59,4	11,9	0,7	0,2	5,0
MQA058 Cereais, “fitness”, special K, prato	A	31	0,5	6,7	1,3	0,1	0,0	0,6
	B	65	1,1	14,2	2,9	0,2	0,1	1,2
	C	115	1,9	25,1	5,0	0,3	0,1	2,1
	D	184	3,0	40,2	8,1	0,5	0,1	3,4
	E	272	4,5	59,4	11,9	0,7	0,2	5,0
MQA059A Cereais, muesli, taça	A	48	1,2	8,7	3,1	0,8	0,1	0,8
	B	100	2,4	18,1	6,5	1,7	0,3	1,6
	C	180	4,4	32,5	11,8	3,0	0,5	2,9
	D	284	6,9	51,3	18,6	4,8	0,8	4,5
	E	429	10,4	77,3	28,0	7,2	1,2	6,8
MQA059B Cereais, muesli, prato	A	48	1,2	8,7	3,1	0,8	0,1	0,8
	B	100	2,4	18,1	6,5	1,7	0,3	1,6
	C	180	4,4	32,5	11,8	3,0	0,5	2,9
	D	289	7,0	52,0	18,9	4,8	0,8	4,6
	E	429	10,4	77,3	28,0	7,2	1,2	6,8

Código e nome da série		Energia (kcal)	Proteína (g)	Hidratos de carbono (g)	Açúcares (g)	Gordura (g)	Ácidos gordos saturados (g)	Fibra (g)
MQA060 Cereais, “cho-capic”, taça	A	32	0,4	6,3	3,1	0,5	0,1	0,3
	B	67	0,9	13,3	6,5	1,0	0,3	0,5
	C	118	1,6	23,6	11,5	1,7	0,4	1,0
	D	189	2,6	37,7	18,3	2,8	0,7	1,5
	E	280	3,8	55,7	27,1	4,1	1,1	2,3
	F	473	6,5	94,2	45,8	7,0	1,8	3,9
MQA061 Cereais, “cho-capic”, prato	A	32	0,4	6,3	3,1	0,5	0,1	0,3
	B	67	0,9	13,3	6,5	1,0	0,3	0,5
	C	118	1,6	23,6	11,5	1,7	0,4	1,0
	D	189	2,6	37,7	18,3	2,8	0,7	1,5
	E	280	3,8	55,7	27,1	4,1	1,1	2,3
	F	473	6,5	94,2	45,8	7,0	1,8	3,9
MQA062 Pão, fatias	A	104	2,6	21,4	0,3	0,5	0,4	1,9
	B	176	4,4	36,2	0,5	0,8	0,7	3,2
	C	146	3,7	30,1	0,4	0,7	0,6	2,7
	D	285	7,2	58,6	0,7	1,3	1,1	5,3
	E	131	3,3	27,0	0,3	0,6	0,5	2,4
	F	226	5,7	46,4	0,6	1,0	0,9	4,2
	G	144	3,6	29,6	0,4	0,6	0,6	2,7
	H	241	6,1	49,5	0,6	1,1	1,0	4,4
MQA062B Pão, inteiro	A	102	2,6	20,9	0,3	0,5	0,4	1,9
	B	127	3,2	26,0	0,3	0,6	0,5	2,3
	C	174	4,4	35,7	0,5	0,8	0,7	3,2
	D	136	3,4	28,1	0,4	0,6	0,6	2,5
	E	99	2,5	20,4	0,3	0,4	0,4	1,8
	F	149	3,7	30,6	0,4	0,7	0,6	2,7
MQA062C Broa, de milho, de avintes, pedaços	A	141	4,5	27,5	1,2	0,9	0,2	2,1
	B	60	1,9	11,7	0,5	0,4	0,1	0,9
	C	190	6,0	37,2	1,6	1,3	0,3	2,8
MQA063A Farinha láctea, “cerelac”, prato	A	29	1,0	4,6	2,5	0,7	0,3	0,2
	B	60	2,1	9,4	5,1	1,4	0,6	0,4
	C	105	3,8	16,6	9,0	2,5	1,1	0,7
	D	168	6,0	26,5	14,4	4,0	1,8	1,2
	E	250	8,9	39,4	21,3	5,9	2,6	1,8
MQA063B Farinha láctea, “cerelac”, taça	A	29	1,0	4,6	2,5	0,7	0,3	0,2
	B	60	2,1	9,4	5,1	1,4	0,6	0,4
	C	105	3,8	16,6	9,0	2,5	1,1	0,7
	D	168	6,0	26,5	14,4	4,0	1,8	1,2
	E	250	8,9	39,4	21,3	5,9	2,6	1,8
MQA064 Nestum, prato	A	54	2,2	9,4	4,7	0,8	0,4	0,2
	B	81	3,3	14,2	7,1	1,2	0,6	0,3
	C	170	6,9	29,5	14,7	2,5	1,3	0,6
	D	302	12,2	52,5	26,1	4,5	2,4	1,1
	E	482	19,5	83,8	41,7	7,2	3,8	1,8

Código e nome da série		Energia (kcal)	Proteína (g)	Hidratos de carbono (g)	Açúcares (g)	Gordura (g)	Ácidos gordos saturados (g)	Fibra (g)
MQA069 Batata, pedaços, cozida	A	31	0,8	6,0	0,4	0,0	0,0	0,5
	B	82	2,2	15,8	1,0	0,0	0,0	1,4
	C	139	3,7	26,7	1,7	0,0	0,0	2,3
	D	221	5,8	42,5	2,7	0,0	0,0	3,7
	E	321	8,5	61,6	3,9	0,0	0,0	5,3
	F	477	12,6	91,6	5,7	0,0	0,0	7,9
MQA112 Salada russa	A	81	2,0	4,3	1,0	5,7	0,4	1,1
	B	169	4,2	8,9	2,0	11,8	0,9	2,3
	C	299	7,5	15,7	3,5	21,0	1,6	4,1
	D	476	11,9	25,0	5,6	33,4	2,6	6,5
	E	709	17,7	37,2	8,3	49,7	3,8	9,7
	F	997	24,9	52,4	11,6	69,9	5,3	13,6
MQA070 Batata frita, palitos	A	64	1,0	7,8	0,5	3,0	0,5	0,7
	B	127	2,0	15,7	1,0	6,0	1,0	1,3
	C	223	3,6	27,4	1,7	10,5	1,7	2,3
	D	362	5,8	44,5	2,8	17,0	2,7	3,7
	E	535	8,6	65,9	4,1	25,2	4,0	5,5
	F	755	12,1	92,9	5,8	35,5	5,7	7,7
MQA071 Batata frita, pacote	A	18	0,4	3,0	0,2	0,4	0,0	0,2
	B	40	0,9	6,7	0,4	1,0	0,1	0,6
	C	67	1,5	11,2	0,7	1,6	0,2	0,9
	D	107	2,3	17,9	1,1	2,6	0,3	1,5
	E	158	3,5	26,5	1,7	3,8	0,4	2,2
	F	221	4,8	37,0	2,3	5,3	0,6	3,1
MQA154 Puré de batata	A	52	1,4	8,0	0,9	1,0	0,6	0,7
	B	147	3,9	22,8	2,7	2,9	1,7	1,9
	C	239	6,3	37,0	4,4	4,7	2,7	3,1
	D	329	8,6	51,1	6,0	6,5	3,7	4,3
	E	476	12,5	73,8	8,7	9,4	5,4	6,1
	F	671	17,6	104,0	12,3	13,3	7,6	8,7
MQA072 Massa, cozida	A	28	0,9	5,3	0,2	0,1	0,0	0,4
	B	57	1,9	10,8	0,5	0,3	0,1	0,8
	C	102	3,4	19,1	0,8	0,5	0,1	1,4
	D	164	5,5	30,7	1,3	0,9	0,2	2,3
	E	243	8,2	45,5	2,0	1,3	0,3	3,4
	F	343	11,5	64,4	2,8	1,8	0,4	4,9
MQA073 Esparguete, cozida	A	36	1,1	6,3	0,3	0,4	0,1	0,5
	B	73	2,3	12,9	0,6	0,9	0,2	1,0
	C	131	4,1	23,0	1,0	1,6	0,3	1,7
	D	209	6,6	36,7	1,6	2,5	0,4	2,8
	E	311	9,8	54,5	2,4	3,8	0,6	4,1
	F	437	13,7	76,7	3,3	5,3	0,9	5,8

Código e nome da série		Energia (kcal)	Proteína (g)	Hidratos de carbono (g)	Açúcares (g)	Gordura (g)	Ácidos gordos saturados (g)	Fibra (g)
MQA076 Massa chinesa, cozida	A	85	3,0	16,0	0,5	0,4	0,1	1,2
	B	179	6,3	33,5	1,1	0,9	0,2	2,6
	C	318	11,1	59,5	1,9	1,6	0,4	4,6
	D	507	17,6	94,6	3,0	2,6	0,6	7,3
	E	753	26,2	140,6	4,4	3,8	0,8	10,8
	F	1062	37,0	198,4	6,2	5,4	1,2	15,2
MQA148 Massa, com vegetais	A	40	1,5	7,4	0,6	0,2	0,0	1,3
	B	87	3,3	16,0	1,4	0,5	0,1	2,7
	C	154	5,8	28,3	2,4	0,8	0,2	4,8
	D	242	9,2	44,7	3,9	1,3	0,2	7,5
	E	361	13,7	66,5	5,7	1,9	0,4	11,2
	F	504	19,2	93,0	8,0	2,7	0,5	15,7
MQA077 Arroz branco, cozido	A	66	1,1	12,7	0,1	1,1	0,2	0,4
	B	141	2,4	27,1	0,2	2,4	0,3	0,8
	C	250	4,2	47,8	0,3	4,3	0,6	1,5
	D	396	6,7	75,9	0,5	6,8	0,9	2,3
	E	589	10,0	112,7	0,7	10,1	1,4	3,4
	F	828	14,0	158,6	1,0	14,2	1,9	4,8
MQA078 Arroz de ervilhas	A	49	1,0	9,1	0,1	0,8	0,1	0,7
	B	101	2,2	18,9	0,3	1,6	0,2	1,4
	C	178	3,8	33,2	0,5	2,8	0,4	2,4
	D	285	6,1	53,1	0,8	4,5	0,6	3,8
	E	423	9,1	78,7	1,2	6,7	1,0	5,7
	F	596	12,8	110,9	1,7	9,4	1,3	8,0
MQA080 Arroz mandro	A	52	0,8	7,2	0,6	2,2	0,3	0,4
	B	108	1,6	15,0	1,2	4,5	0,6	0,9
	C	192	2,8	26,6	2,1	7,9	1,1	1,6
	D	309	4,6	42,7	3,4	12,7	1,8	2,5
	E	459	6,8	63,4	5,0	18,9	2,7	3,8
	F	645	9,5	89,1	7,0	26,6	3,8	5,3
MQA145 Migas, c/ grelos	A	55	2,1	7,6	0,5	1,5	0,3	1,0
	B	101	3,9	14,1	0,9	2,8	0,5	1,9
	C	213	8,2	29,6	2,0	6,0	1,0	4,0
	D	446	17,2	62,0	4,2	12,5	2,1	8,3
	E	790	30,4	110,0	7,4	22,1	3,8	14,8
	F	1262	48,6	175,7	11,8	35,3	6,0	23,6
MQA084 Açorda alentejana, tipo migas	A	44	1,4	4,6	0,2	2,0	0,2	0,4
	B	91	2,8	9,6	0,4	4,2	0,5	0,7
	C	161	5,0	17,1	0,7	7,4	0,8	1,3
	D	256	8,0	27,2	1,1	11,8	1,3	2,1
	E	380	11,9	40,3	1,6	17,5	2,0	3,1
	F	537	16,8	56,8	2,3	24,6	2,8	4,3

Código e nome da série		Energia (kcal)	Proteína (g)	Hidratos de carbono (g)	Açúcares (g)	Gordura (g)	Ácidos gordos saturados (g)	Fibra (g)
MQA052 Presunto, fatias	A	24	2,8	0,0	0,0	1,4	0,5	0,0
	B	47	5,5	0,0	0,0	2,8	0,9	0,0
	C	86	10,0	0,0	0,0	5,1	1,6	0,0
	D	138	16,0	0,0	0,0	8,2	2,6	0,0
	E	204	23,8	0,0	0,0	12,2	3,9	0,0
MQA053 Fiambre, fatias	A	11	1,7	0,2	0,2	0,3	0,0	0,0
	B	24	3,9	0,4	0,4	0,8	0,1	0,0
	C	41	6,7	0,7	0,7	1,3	0,1	0,0
	D	69	11,1	1,1	1,1	2,2	0,2	0,0
	E	102	16,6	1,7	1,7	3,2	0,3	0,0
MQA054 Chouriço, Linguiça, rodelas	A	43	1,8	0,0	0,0	4,0	1,4	0,0
	B	86	3,6	0,0	0,0	7,9	2,7	0,0
	C	143	6,0	0,0	0,0	13,2	4,6	0,0
	D	229	9,6	0,0	0,0	21,1	7,3	0,0
	E	333	14,0	0,0	0,0	30,8	10,6	0,0
	F	467	19,6	0,0	0,0	43,2	14,9	0,0
MQA085 Bife	A	53	8,7	0,0	0,0	1,5	0,8	0,0
	B	99	16,1	0,0	0,0	2,8	1,5	0,0
	C	174	28,2	0,0	0,0	4,9	2,6	0,0
	D	288	46,7	0,0	0,0	8,1	4,2	0,0
	E	417	67,7	0,0	0,0	11,7	6,1	0,0
	F	585	94,9	0,0	0,0	16,4	8,6	0,0
MQA087 Carne, pedaços, cozida	A	90	10,1	0,0	0,0	3,8	2,0	0,0
	B	195	21,7	0,0	0,0	8,2	4,2	0,0
	C	349	38,9	0,0	0,0	14,6	7,6	0,0
	D	558	62,3	0,0	0,0	23,4	12,1	0,0
	E	825	92,1	0,0	0,0	34,7	17,9	0,0
	F	1162	129,7	0,0	0,0	48,8	25,2	0,0
MQA088 Carne, com ervilhas e cenouras, estufada	A	94	7,0	1,7	0,9	6,2	2,1	1,1
	B	203	15,1	3,6	2,0	13,4	4,4	2,4
	C	355	26,5	6,3	3,5	23,4	7,8	4,2
	D	571	42,6	10,1	5,7	37,6	12,5	6,7
	E	821	61,2	14,5	8,2	54,0	17,9	9,7
	F	1161	86,5	20,5	11,6	76,4	25,4	13,7
MQA104 Jardineira, batata e carne estufada	A	67	5,1	4,5	0,9	2,9	0,8	1,1
	B	147	11,1	9,8	1,9	6,3	1,9	2,3
	C	257	19,4	17,1	3,4	11,1	3,2	4,0
	D	407	30,7	27,1	5,4	17,6	5,1	6,4
	E	600	45,3	40,0	8,0	25,9	7,6	9,4
	F	834	63,0	55,5	11,1	36,0	10,6	13,1

Código e nome da série		Energia (kcal)	Proteína (g)	Hidratos de carbono (g)	Açúcares (g)	Gordura (g)	Ácidos gordos saturados (g)	Fibra (g)
MQA105 Chili	A	68	6,6	4,2	0,5	2,6	0,9	0,7
	B	144	13,8	8,8	1,0	5,4	1,9	1,5
	C	256	24,6	15,7	1,7	9,6	3,3	2,6
	D	408	39,2	25,0	2,8	15,4	5,3	4,2
	E	606	58,2	37,2	4,1	22,8	7,9	6,2
	F	853	81,9	52,3	5,8	32,1	11,1	8,8
MQA086 Costeleta, com osso, grelhada	A	36	3,0	0,0	0,0	2,0	0,9	0,0
	B	67	5,6	0,0	0,0	3,8	1,6	0,0
	C	81	6,9	0,0	0,0	4,6	2,0	0,0
	D	157	13,3	0,1	0,0	8,9	3,8	0,0
	E	245	20,8	0,1	0,1	13,9	6,0	0,0
	F	552	46,8	0,3	0,1	31,4	13,4	0,1
MQA159 Entremeada	A	38	2,3	0,1	0,1	2,5	1,1	0
	B	73	4,3	0,2	0,1	4,8	2,2	0
	C	166	9,9	0,4	0,3	11	5	0
	D	343	20,4	0,8	0,6	22,7	10,3	0
	E	509	30,3	1,3	0,9	33,7	15,2	0
	F	759	45,1	1,9	1,4	50,2	22,7	0
	G	1106	65,7	2,7	2,1	73,1	33	0
MQA162 Entrecosto	A	115	8,7	0	0	6,9	2,6	0
	B	241	18,3	0	0	14,5	5,4	0
	C	440	33,4	0	0	26,5	9,8	0
	D	701	53,2	0	0	42,3	15,6	0
	E	1035	78,5	0	0	62,4	23	0
	F	1475	111,9	0	0	88,9	32,8	0
MQA155 Espetadas mistas, c/ espeto	A	78	11,9	0,3	0,3	2,9	1,1	0,2
	B	138	21,2	0,6	0,5	5,1	2,0	0,3
	C	278	42,7	1,2	0,9	10,3	4,0	0,6
	D	424	65,1	1,8	1,4	15,8	6,1	1,0
	E	556	85,4	2,4	1,9	20,7	8,1	1,3
MQA155B Espetadas mistas, s/ espeto	A	78	11,9	0,3	0,3	2,9	1,1	0,2
	B	138	21,2	0,6	0,5	5,1	2,0	0,3
	C	278	42,7	1,2	0,9	10,3	4,0	0,6
	D	424	65,1	1,8	1,4	15,8	6,1	1,0
	E	556	85,4	2,4	1,9	20,7	8,1	1,3
MQA089 Carne, fatias, assada	A	33	3,6	0,4	0,3	1,8	0,4	0,2
	B	74	7,9	0,8	0,6	4,0	0,9	0,4
	C	155	16,7	1,7	1,3	8,5	1,8	0,9
	D	233	25,1	2,5	2,0	12,8	2,8	1,3
	E	312	33,6	3,4	2,7	17,2	3,7	1,8
	F	482	51,9	5,2	4,1	26,5	5,7	2,8

Código e nome da série		Energia (kcal)	Proteína (g)	Hidratos de carbono (g)	Açúcares (g)	Gordura (g)	Ácidos gordos saturados (g)	Fibra (g)
MQA163 Rolo de Carne	A	66	8,0	0,0	0,0	3,6	1,4	0,0
	B	187	22,6	0,1	0,0	10,3	4,0	0,0
	C	298	36,0	0,2	0,0	16,4	6,4	0,1
	D	492	59,4	0,4	0,0	27,0	10,5	0,1
	E	693	83,7	0,5	0,1	38,1	14,8	0,1
	F	992	119,7	0,7	0,1	54,5	21,1	0,2
MQA157 Panados de carne	A	44	4,8	3,5	0,1	1,2	0,2	0,2
	B	112	12,1	8,7	0,3	3,0	0,5	0,4
	C	205	22,1	16,0	0,5	5,4	0,9	0,7
	D	403	43,5	31,5	1,0	10,7	1,8	1,4
	E	606	65,3	47,3	1,5	16,1	2,8	2,1
	F	844	91,0	66,0	2,1	22,4	3,9	2,9
MQA091 Rojões	A	66	8,1	0,1	0,0	3,4	1,0	0,0
	B	131	16,2	0,2	0,0	6,9	2,1	0,0
	C	232	28,6	0,3	0,1	12,1	3,7	0,0
	D	371	45,8	0,5	0,1	19,4	5,9	0,0
	E	548	67,7	0,7	0,2	28,7	8,7	0,1
	F	776	95,9	1,1	0,3	40,7	12,3	0,1
MQA102 Bifanas	A	107	5,1	2,4	2,3	6,5	1,9	0,0
	B	227	10,8	5,2	4,8	13,8	4,1	0,0
	C	401	19,0	9,1	8,5	24,3	7,3	0,1
	D	646	30,6	14,6	13,7	39,1	11,7	0,1
	E	950	45,1	21,5	20,2	57,5	17,2	0,2
	F	1341	63,6	30,4	28,5	81,1	24,2	0,3
MQA100 Tripas à moda do Porto	A	192	12,6	9,0	0,9	10,2	3,5	4,9
	B	413	27,1	19,3	2,0	21,9	7,6	10,6
	C	715	47,0	33,4	3,5	37,9	13,2	18,4
	D	1139	74,9	53,2	5,5	60,4	21,0	29,3
	E	1688	111,0	78,9	8,1	89,5	31,2	43,5
	F	1945	127,9	90,9	9,4	103,1	35,9	50,1
MQA110 Feijoada de carnes	A	130	7,9	7,6	0,4	7,1	2,0	1,2
	B	271	16,5	15,9	0,9	14,8	4,2	2,6
	C	482	29,3	28,3	1,5	26,3	7,5	4,6
	D	769	46,7	45,2	2,5	42,0	12,0	7,3
	E	1141	69,3	67,0	3,6	62,3	17,8	10,9
	F	1607	97,6	94,4	5,1	87,8	25,1	15,3
MQA103 Carne de porco à Alentejana	A	249	4,4	0,4	0,2	24,5	6,9	0,1
	B	502	8,9	0,8	0,3	49,3	13,8	0,1
	C	894	15,9	1,3	0,6	87,8	24,6	0,3
	D	1425	25,3	2,1	0,9	139,9	39,3	0,4
	E	2127	37,8	3,2	1,4	208,9	58,6	0,6
	F	3030	53,8	4,6	1,9	297,5	83,5	0,9

Código e nome da série		Energia (kcal)	Proteína (g)	Hidratos de carbono (g)	Açúcares (g)	Gordura (g)	Ácidos gordos saturados (g)	Fibra (g)
MQA106 Strogonoff de carne	A	98	6,8	1,3	1,2	7,0	3,3	0,3
	B	208	14,3	2,8	2,6	14,8	7,0	0,7
	C	358	24,7	4,9	4,4	25,5	12,0	1,2
	D	572	39,4	7,8	7,1	40,7	19,2	1,8
	E	851	58,6	11,6	10,5	60,6	28,6	2,7
	F	1264	87,1	17,2	15,7	90,1	42,5	4,1
MQA107 Carne, com batatas, estufada	A	106	5,8	4,7	1,0	6,3	1,5	0,6
	B	223	12,1	9,9	2,2	13,2	3,2	1,3
	C	394	21,5	17,4	3,8	23,4	5,6	2,4
	D	629	34,3	27,9	6,1	37,4	9,0	3,8
	E	933	50,8	41,3	9,1	55,4	13,3	5,6
	F	1315	71,6	58,2	12,8	78,1	18,8	7,9
MQA090 Frango, assado	A	93	8,6	0,1	0,0	5,0	1,5	0,0
	B	193	17,8	0,1	0,0	10,3	3,0	0,0
	C	341	31,4	0,2	0,0	18,2	5,3	0,0
	D	545	50,2	0,3	0,1	29,1	8,5	0,0
	E	818	75,3	0,5	0,1	43,6	12,8	0,0
	F	1136	104,5	0,7	0,1	60,6	17,8	0,1
MQA099 Frango estufado, c/ molho	A	123	9,4	1,4	0,8	8,5	1,9	0,8
	B	301	22,9	3,5	1,8	20,8	4,7	2,0
	C	508	38,7	5,8	3,1	35,1	7,9	3,4
	D	735	56,0	8,4	4,5	50,7	11,4	5,0
	E	1147	87,4	13,2	7,0	79,1	17,8	7,8
	F	1605	122,3	18,4	9,8	110,7	24,9	10,9
MQA101B Moelas, c/ molho	A	38	2,8	0,9	0,7	1,9	0,4	0,2
	B	78	5,7	1,9	1,4	3,9	0,8	0,3
	C	138	10,1	3,4	2,5	7,0	1,5	0,6
	D	219	16,1	5,4	3,9	11,1	2,4	1,0
	E	324	23,8	8,1	5,8	16,4	3,5	1,5
	F	457	33,5	11,4	8,2	23,1	5,0	2,1
MQA111 Cozido à Portuguesa	A	124	10,1	7,8	1,2	3,7	1,8	1
	B	260	21,2	16,3	2,5	7,8	3,7	2,1
	C	465	37,9	29,1	4,4	13,9	6,7	3,8
	D	731	59,6	45,8	6,9	21,9	10,5	6
	E	990	80,7	62,1	9,4	29,6	14,2	8,1
MQA144 Migas, à alentejana	A	192	9,6	22,2	0,9	6,7	2,2	1,5
	B	401	20	46,5	1,8	14	4,6	3,2
	C	712	35,5	82,4	3,3	24,7	8,1	5,7
	D	1137	56,8	131,7	5,2	39,5	13	9,1
	E	1687	84,2	195,3	7,7	58,6	19,3	13,5
	F	2377	118,6	275,2	10,9	82,6	27,1	19

Código e nome da série		Energia (kcal)	Proteína (g)	Hidratos de carbono (g)	Açúcares (g)	Gordura (g)	Ácidos gordos saturados (g)	Fibra (g)
MQA093 Rancho	A	288	10,5	15,3	1,2	19,8	5,3	2,6
	B	616	22,4	32,6	2,6	42,2	11,3	5,6
	C	1090	39,7	57,8	4,6	74,7	20,1	9,9
	D	1731	63,0	91,7	7,2	118,5	31,9	15,7
	E	2603	94,7	137,9	10,9	178,3	47,9	23,6
MQA153 Massa com carne ou peixe	A	194	11,4	20,0	1,6	6,8	1,9	1,4
	B	346	20,2	35,6	2,9	12,1	3,5	2,5
	C	554	32,3	57,0	4,7	19,4	5,5	4,0
	D	828	48,3	85,1	7,0	29,0	8,3	5,9
	E	1327	77,5	136,5	11,2	46,5	13,3	9,5
	F	1972	115,1	202,8	16,6	69,1	19,7	14,2
MQA097 Empadão de carne	A	131	8,8	8,8	1,7	5,6	2,0	0,9
	B	298	19,9	20,0	3,9	12,8	4,5	2,1
	C	482	32,1	32,2	6,3	20,6	7,2	3,5
	D	842	56,1	56,4	11,0	36,1	12,6	6,1
	E	1206	80,3	80,8	15,7	51,7	18,1	8,7
MQA074 Esparguete, bolonhesa	A	186	11,7	12,3	3,8	9,4	3,2	1,1
	B	407	25,6	26,8	8,2	20,4	7,1	2,5
	C	697	43,8	45,9	14,1	35,0	12,1	4,2
	D	1104	69,4	72,7	22,3	55,3	19,2	6,7
	E	1651	103,7	108,8	33,3	82,8	28,7	10,0
	F	2314	145,4	152,5	46,7	116,0	40,2	14,1
MQA075 Esparguete, carbonara	A	125	4,2	9,5	0,8	7,4	3,2	0,7
	B	264	8,8	20,0	1,6	15,5	6,8	1,5
	C	468	15,5	35,5	2,8	27,5	12,0	2,6
	D	746	24,8	56,7	4,5	43,8	19,2	4,1
	E	1107	36,8	84,1	6,7	65,1	28,5	6,1
	F	1560	51,8	118,5	9,4	91,7	40,1	8,6
MQA081 Lasanha	A	67	4,1	6,6	1,5	2,5	0,9	0,5
	B	151	9,2	14,8	3,3	5,6	2,0	1,0
	C	246	15,0	24,1	5,4	9,1	3,2	1,7
	D	403	24,5	39,5	8,9	14,9	5,3	2,8
	E	578	35,1	56,6	12,8	21,4	7,6	3,9
	F	859	52,2	84,1	19,0	31,8	11,3	5,9
MQA082 Ravioli	A	66	2,1	7,0	0,8	3,1	0,7	0,6
	B	119	3,7	12,4	1,4	5,5	1,2	1,0
	C	246	7,7	25,8	2,9	11,4	2,5	2,1
	D	431	13,5	45,2	5,1	20,0	4,3	3,6
	E	695	21,7	72,8	8,3	32,3	7,0	5,8
	F	1044	32,6	109,4	12,4	48,5	10,5	8,8

Código e nome da série		Energia (kcal)	Proteína (g)	Hidratos de carbono (g)	Açúcares (g)	Gordura (g)	Ácidos gordos saturados (g)	Fibra (g)
MQA113 Peixe, filete	A	72	6,3	7,0	0,0	2,0	0,2	0,2
	B	126	11,1	12,3	0,0	3,5	0,4	0,4
	C	196	17,2	19,1	0,0	5,5	0,7	0,7
	D	320	28,1	31,1	0,0	9,0	1,1	1,1
	E	511	44,9	49,7	0,0	14,4	1,8	1,7
MQA114 Peixe, postas finas	A	126	7,4	0,1	0,1	8,4	2,0	0,1
	B	274	16,1	0,2	0,2	18,2	4,4	0,2
	C	470	27,6	0,4	0,4	31,3	7,5	0,3
	D	772	45,3	0,6	0,6	51,4	12,3	0,4
	E	1091	64,0	0,9	0,9	72,6	17,4	0,6
	F	1590	93,2	1,3	1,3	105,8	25,4	0,9
MQA115 Peixe, postas grossas	A	45	7,2	0,0	0,0	0,7	0,1	0,0
	B	118	18,8	0,0	0,0	1,8	0,3	0,0
	C	165	26,3	0,0	0,0	2,5	0,4	0,0
	D	235	37,4	0,0	0,0	3,6	0,6	0,0
MQA121 Peixes pequenos, fritos	A	80	3,3	1,2	0,0	6,8	1,3	0,0
	B	157	6,5	2,4	0,0	13,5	2,5	0,1
	C	275	11,5	4,2	0,1	23,6	4,4	0,2
	D	446	18,6	6,8	0,1	38,3	7,1	0,3
	E	658	27,4	10,0	0,2	56,4	10,5	0,4
	F	915	38,0	13,9	0,3	78,4	14,6	0,5
MQA122 Peixe, inteiro, grelhado	A	131	21,6	0,0	0,0	4,2	0,9	0,0
	B	181	29,9	0,0	0,0	5,8	1,3	0,0
	C	231	38,2	0,0	0,0	7,5	1,7	0,0
MQA126 Caldeirada de peixe	A	105	6,7	7,2	1,6	5,2	0,9	1,1
	B	221	14,1	15,2	3,3	11,0	2,0	2,2
	C	390	24,9	26,9	5,8	19,5	3,5	4,0
	D	623	39,8	42,9	9,3	31,0	5,5	6,3
	E	925	59,1	63,7	13,8	46,1	8,2	9,4
	F	1303	83,2	89,8	19,4	65,0	11,6	13,3
MQA116 Bacalhau com cebolada	A	115	9,9	1,4	0,8	7,6	1,1	0,5
	B	177	15,3	2,1	1,2	11,8	1,7	0,8
	C	196	16,9	2,4	1,3	13	1,9	0,9
	D	289	24,9	3,5	1,9	19,2	2,8	1,3
	E	297	25,6	3,6	2	19,8	2,9	1,3
	F	582	50,1	7	3,9	38,7	5,7	2,6
MQA117 Bacalhau com grão de bico	A	157	8,5	10,4	0,9	7,6	0,9	3,0
	B	325	17,7	21,5	1,9	15,7	1,9	6,2
	C	577	31,4	38,2	3,4	27,9	3,3	11,0
	D	921	50,1	60,9	5,5	44,6	5,2	17,6
	E	1368	74,4	90,5	8,2	66,2	7,8	26,2
	F	1926	104,7	127,4	11,5	93,1	11,0	36,9

Código e nome da série		Energia (kcal)	Proteína (g)	Hidratos de carbono (g)	Açúcares (g)	Gordura (g)	Ácidos gordos saturados (g)	Fibra (g)
MQA118 Bacalhau com natas	A	119	6,6	8,5	2,2	5,7	2,7	0,6
	B	180	10,0	12,9	3,3	8,7	4,1	0,9
	C	320	17,8	22,9	5,9	15,4	7,4	1,7
	D	512	28,6	36,8	9,4	24,7	11,8	2,7
	E	779	43,5	55,9	14,3	37,5	18,0	4,1
	F	1190	66,4	85,4	21,9	57,3	27,4	6,2
MQA119 Bacalhau espiritual	A	106	9,9	6,7	1,0	4,2	1,6	0,8
	B	172	16,1	10,8	1,7	6,8	2,5	1,4
	C	329	30,8	20,6	3,2	13,0	4,9	2,6
	D	590	55,4	37,0	5,7	23,4	8,7	4,7
	E	910	85,3	57,0	8,8	36,1	13,5	7,3
	F	1422	133,4	89,2	13,8	56,5	21,1	11,3
MQA120 Bacalhau à Gomes de Sá	A	99	3,9	4,0	1,5	6,8	1,1	0,6
	B	144	5,7	5,8	2,2	9,9	1,5	0,9
	C	312	12,4	12,7	4,8	21,6	3,4	2,0
	D	531	21,1	21,6	8,2	36,8	5,7	3,4
	E	836	33,2	33,9	12,8	57,9	9,0	5,4
	F	1256	49,9	50,9	19,3	86,9	13,5	8,1
MQA156 Pataniscas de bacalhau	A	59	4,0	4,7	0,1	2,7	0,5	0,2
	B	126	8,5	10,0	0,3	5,7	1,1	0,4
	C	207	13,9	16,4	0,5	9,4	1,8	0,7
	D	323	21,7	25,6	0,7	14,6	2,8	1,1
	E	480	32,2	37,9	1,1	21,7	4,1	1,7
	F	692	46,4	54,7	1,6	31,3	6,0	2,4
MQA098 Bacalhau, à Brás	A	40	3,2	2,5	0,5	1,8	0,3	0,5
	B	66	5,3	4,2	0,8	2,9	0,6	0,8
	C	136	10,9	8,6	1,7	6,1	1,2	1,6
	D	241	19,4	15,3	3,1	10,8	2,1	2,9
	E	385	31,0	24,4	4,9	17,2	3,4	4,6
	F	573	46,0	36,3	7,3	25,5	5,1	6,9
MQA092 Roupa velha	A	74	5,9	3,0	0,6	3,3	0,4	0,6
	B	149	11,8	5,9	1,3	6,6	0,8	1,2
	C	264	21,0	10,5	2,2	11,8	1,5	2,1
	D	421	33,4	16,8	3,6	18,8	2,4	3,3
	E	624	49,6	24,9	5,3	27,8	3,5	4,9
MQA123 Mexilhão, s/ concha	A	12	2,1	0,4	0,0	0,3	0,1	0,0
	B	26	4,5	0,7	0,0	0,6	0,1	0,0
	C	45	7,8	1,3	0,0	1,0	0,2	0,0
	D	72	12,5	2,1	0,0	1,5	0,3	0,0
	E	107	18,5	3,1	0,0	2,3	0,5	0,0
	F	151	26,2	4,3	0,0	3,2	0,6	0,0

Código e nome da série		Energia (kcal)	Proteína (g)	Hidratos de carbono (g)	Açúcares (g)	Gordura (g)	Ácidos gordos saturados (g)	Fibra (g)
MQA123B Mexilhão, s/ concha, c/ molho	A	13	1,7	0,3	0,0	0,6	0,1	0,0
	B	28	3,6	0,7	0,1	1,2	0,2	0,1
	C	49	6,2	1,2	0,1	2,1	0,3	0,1
	D	78	10,0	1,9	0,2	3,3	0,5	0,2
	E	115	14,8	2,8	0,3	4,9	0,8	0,3
	F	163	20,9	4,0	0,5	6,9	1,1	0,4
MQA123C Mexilhão, c/ concha	A	8	1,4	0,2	0,0	0,2	0,0	0,0
	B	17	3,0	0,5	0,0	0,4	0,1	0,0
	C	30	5,2	0,9	0,0	0,6	0,1	0,0
	D	49	8,5	1,4	0,0	1,1	0,2	0,0
	E	73	12,7	2,1	0,0	1,6	0,3	0,0
	F	91	15,7	2,6	0,0	2,0	0,4	0,0
MQA123D Mexilhão, c/ concha, c/molho	A	9	1,2	0,2	0,0	0,4	0,1	0,0
	B	19	2,4	0,5	0,1	0,8	0,1	0,0
	C	33	4,2	0,8	0,1	1,4	0,2	0,1
	D	54	6,9	1,3	0,2	2,3	0,4	0,1
	E	80	10,3	2,0	0,2	3,4	0,6	0,2
	F	100	12,9	2,4	0,3	4,3	0,7	0,3
MQA124 Camarão	A	4	0,7	0,0	0,0	0,0	0,0	0,0
	B	9	1,5	0,0	0,0	0,1	0,0	0,0
	C	15	2,6	0,1	0,0	0,1	0,0	0,0
	D	24	4,1	0,1	0,0	0,2	0,0	0,0
	E	36	6,2	0,1	0,0	0,3	0,0	0,0
	F	53	9,0	0,2	0,0	0,4	0,1	0,0
	G	87	14,9	0,3	0,0	0,7	0,1	0,0
MQA108 Chop suey	A	33	2,3	2,9	2,7	1,1	0,1	0,7
	B	69	4,8	5,9	5,6	2,2	0,2	1,5
	C	124	8,6	10,6	10,1	4,0	0,4	2,6
	D	200	13,9	17,1	16,3	6,4	0,7	4,2
	E	296	20,6	25,3	24,0	9,5	1,1	6,2
	F	414	28,8	35,4	33,6	13,3	1,5	8,7
MQA125 Calamares	A	92	5,3	2,1	0,1	6,1	0,9	0,1
	B	188	10,9	4,3	0,1	12,5	1,9	0,2
	C	313	18,1	7,1	0,2	20,8	3,1	0,3
	D	537	31,0	12,1	0,4	35,6	5,4	0,5
	E	739	42,7	16,7	0,6	49,1	7,4	0,7
	F	1066	61,6	24,1	0,8	70,8	10,7	1,0
MQA129 Lulas, grelhadas	A	29	6,2	0,0	0,0	0,4	0,1	0,0
	B	61	12,9	0,0	0,0	0,8	0,2	0,0
	C	109	23,0	0,0	0,0	1,4	0,3	0,0
	D	175	36,8	0,0	0,0	2,2	0,5	0,0
	E	259	54,5	0,0	0,0	3,3	0,7	0,0
	F	365	76,8	0,0	0,0	4,6	1,0	0,0

Código e nome da série		Energia (kcal)	Proteína (g)	Hidratos de carbono (g)	Açúcares (g)	Gordura (g)	Ácidos gordos saturados (g)	Fibra (g)
MQA127 Lulas estufadas, com legumes	A	43	4,2	0,7	0,6	2,4	0,4	0,3
	B	90	8,9	1,5	1,3	5,1	0,8	0,7
	C	158	15,5	2,6	2,3	8,9	1,4	1,2
	D	251	24,7	4,2	3,6	14,2	2,2	2,0
	E	378	37,1	6,3	5,4	21,4	3,2	3,0
	F	528	51,8	8,8	7,6	29,9	4,5	4,1
MQA128 Polvo, cozido	A	39	8,4	0,0	0,0	0,6	0,2	0,0
	B	82	17,4	0,0	0,0	1,3	0,3	0,0
	C	143	30,5	0,0	0,0	2,3	0,6	0,0
	D	233	49,7	0,0	0,0	3,8	1,0	0,0
	E	347	74,0	0,0	0,0	5,7	1,4	0,0
	F	487	103,8	0,0	0,0	8,0	2,0	0,0
MQA079 Arroz de polvo	A	99	4,8	14,9	0,4	0,9	0,2	0,5
	B	210	10,3	31,7	0,9	2,0	0,4	1,1
	C	368	18,0	55,7	1,6	3,5	0,6	2,0
	D	586	28,7	88,6	2,5	5,5	1,0	3,2
	E	871	42,7	131,7	3,7	8,2	1,5	4,8
MQA152 Arroz de peixe	A	59	2,2	8,8	0,4	1,6	0,2	0,4
	B	113	4,2	16,8	0,7	3,1	0,4	0,8
	C	287	10,7	42,6	1,8	7,8	1,1	2,1
	D	442	16,4	65,4	2,8	12,0	1,7	3,2
	E	770	28,6	114,0	4,9	20,9	3,0	5,6
	F	1177	43,7	174,4	7,5	31,9	4,6	8,6
MQA146 Tortilha	A	184	5,9	11,9	1,3	12,2	2,3	1,3
	B	388	12,5	25,0	2,6	25,7	4,8	2,6
	C	691	22,2	44,5	4,7	45,7	8,6	4,7
	D	1119	36,0	72,1	7,6	74,0	13,9	7,6
	E	1671	53,7	107,7	11,4	110,5	20,7	11,4
	F	2234	71,8	144,0	15,2	147,7	27,7	15,2
MQA147A Ovos mexidos	A	52	3,5	0,0	0,0	4,1	0,9	0,0
	B	109	7,4	0,0	0,0	8,6	1,9	0,0
	C	191	13,1	0,0	0,0	15,1	3,4	0,0
	D	306	20,9	0,0	0,0	24,2	5,4	0,0
	E	453	30,9	0,0	0,0	35,8	8,0	0,0
	F	642	43,9	0,0	0,0	50,8	11,4	0,0
MQA026 Queijo fresco, feta, tofu, fatias	A	12	1,3	0,1	0,0	0,7	0,1	0,0
	B	20	2,2	0,2	0,1	1,1	0,2	0,1
	C	38	4,2	0,3	0,1	2,2	0,3	0,1
	D	65	7,2	0,6	0,3	3,7	0,5	0,3
	E	100	11,1	0,9	0,4	5,7	0,8	0,4
MQA027 Queijo fresco, inteiro	A	119	7,2	1,2	0,9	9,5	5,2	0,0
	B	239	14,5	2,4	1,8	19,0	10,3	0,0
	C	597	36,2	6,0	4,6	47,6	25,8	0,0

Código e nome da série		Energia (kcal)	Proteína (g)	Hidratos de carbono (g)	Açúcares (g)	Gordura (g)	Ácidos gordos saturados (g)	Fibra (g)
MQA028 Requeijão, inteiro	A	84	5,2	2,2	2,2	6,0	3,2	0,0
	B	168	10,5	4,5	4,5	12,0	6,5	0,0
	C	336	21,0	9,0	9,0	24,0	13,0	0,0
MQA029 Queijo saloio	A	113	7,4	0,1	0,1	9,1	4,8	0,0
	B	187	12,2	0,1	0,1	15,1	8,0	0,0
	C	214	14,0	0,1	0,1	17,3	9,1	0,0
	D	366	24,0	0,2	0,2	29,6	15,6	0,0
	E	424	27,8	0,2	0,2	34,3	18,1	0,0
	F	732	47,9	0,4	0,4	59,2	31,2	0,0
MQA048 Queijo brie, queijo camembert	A	30	2,3	0,0	0,0	2,4	1,3	0,0
	B	56	4,2	0,0	0,0	4,3	2,3	0,0
	C	102	7,7	0,1	0,1	7,8	4,2	0,0
	D	157	11,9	0,1	0,1	12,2	6,5	0,0
	E	236	17,9	0,2	0,2	18,2	9,8	0,0
MQA049 Queijo da ilha, queijo manchego	A	47	4,1	0,0	0,0	3,3	1,8	0,0
	B	75	6,6	0,0	0,0	5,4	2,9	0,0
	C	143	12,6	0,1	0,1	10,3	5,5	0,0
	D	229	20,2	0,1	0,1	16,4	8,8	0,0
	E	344	30,2	0,2	0,2	24,7	13,2	0,0
	F	512	45,0	0,3	0,3	36,8	19,7	0,0
MQA050 Queijo chevre, rolo, fatias	A	32	1,8	0,0	0,0	2,6	1,7	0,0
	B	67	3,8	0,0	0,0	5,5	3,7	0,0
	C	115	6,5	0,0	0,0	9,4	6,3	0,0
	D	154	8,7	0,0	0,0	12,7	8,5	0,0
	E	249	14,1	0,1	0,1	20,5	13,7	0,0
	F	368	20,8	0,1	0,1	30,2	20,2	0,0
MQA051 Queijo flamengo, fatias	A	31	3,1	0,0	0,0	2,1	1,1	0,0
	B	65	6,4	0,0	0,0	4,3	2,3	0,0
	C	110	10,9	0,1	0,1	7,3	3,9	0,0
	D	180	17,9	0,1	0,1	12,0	6,4	0,0
	E	270	26,9	0,2	0,2	18,0	9,6	0,0
MQA066 Manteiga	A	18	0,0	0,0	0,0	2,0	1,2	0,0
	B	37	0,0	0,0	0,0	4,1	2,3	0,0
	C	74	0,0	0,1	0,1	8,2	4,6	0,0
	D	111	0,0	0,1	0,1	12,3	6,9	0,0
	E	148	0,0	0,1	0,1	16,4	9,3	0,0
MQA067 Manteiga, em pão	A	18	0,0	0,0	0,0	2,0	1,2	0,0
	B	37	0,0	0,0	0,0	4,1	2,3	0,0
	C	74	0,0	0,1	0,1	8,2	4,6	0,0
	D	111	0,0	0,1	0,1	12,3	6,9	0,0
	E	148	0,0	0,1	0,1	16,4	9,3	0,0

Código e nome da série		Energia (kcal)	Proteína (g)	Hidratos de carbono (g)	Açúcares (g)	Gordura (g)	Ácidos gordos saturados (g)	Fibra (g)
MQA068A Doce, Com-pota, pão	A	13	0,0	3,1	3,1	0,0	0,0	0,1
	B	26	0,0	6,5	6,5	0,0	0,0	0,1
	C	48	0,0	11,8	11,8	0,0	0,0	0,2
	D	76	0,0	18,9	18,9	0,0	0,0	0,3
	E	112	0,0	27,7	27,7	0,0	0,0	0,5
MQA068B Doce, Com-pota, prato	A	13	0,0	3,1	3,1	0,0	0,0	0,1
	B	26	0,0	6,5	6,5	0,0	0,0	0,1
	C	48	0,0	11,8	11,8	0,0	0,0	0,2
	D	76	0,0	18,9	18,9	0,0	0,0	0,3
	E	112	0,0	27,7	27,7	0,0	0,0	0,5
MQA130 Bolo leve, pão de ló	A	41	1,0	8,0	5,0	0,6	0,0	0,1
	B	91	2,2	17,7	11,0	1,2	0,0	0,3
	C	124	3,1	24,1	15,0	1,7	0,0	0,4
	D	227	5,6	43,9	27,4	3,0	0,0	0,7
	E	359	8,9	69,6	43,4	4,8	0,1	1,1
	F	503	12,4	97,4	60,8	6,7	0,1	1,5
MQA131 Bolo denso, de ananás	A	79	1,0	11,1	7,3	3,3	0,3	0,2
	B	178	2,3	24,9	16,4	7,5	0,7	0,5
	C	292	3,8	40,9	27,0	12,3	1,2	0,9
	D	450	5,9	63,2	41,7	18,9	1,9	1,4
	E	641	8,3	89,8	59,3	26,9	2,6	2,0
	F	862	11,2	121,0	79,8	36,3	3,6	2,6
MQA132 Bolo rei	A	94	1,8	13,8	5,1	3,1	1,0	1,1
	B	137	2,6	20,2	7,5	4,5	1,5	1,6
	C	308	5,8	45,3	16,9	10,1	3,4	3,7
	D	465	8,8	68,5	25,5	15,2	5,2	5,6
	E	686	13,0	101,0	37,6	22,4	7,6	8,2
	F	971	18,4	142,8	53,2	31,7	10,8	11,6
MQA140 Bolo de bolacha	A	68	1,9	7,2	2,8	3,4	1,5	0,2
	B	125	3,4	13,3	5,1	6,3	2,7	0,3
	C	182	5,0	19,4	7,4	9,2	3,9	0,5
	D	275	7,6	29,4	11,2	14,0	5,9	0,8
	E	405	11,2	43,2	16,5	20,6	8,7	1,1
	F	675	18,6	72,1	27,5	34,3	14,5	1,9
MQA133 Tarte fina	A	57	0,6	7,4	3,9	2,7	1,4	0,5
	B	112	1,1	14,5	7,6	5,2	2,7	0,9
	C	199	2,0	26,0	13,6	9,3	4,9	1,7
	D	309	3,1	40,2	21,0	14,4	7,5	2,6
	E	439	4,4	57,2	29,9	20,5	10,7	3,7
	F	665	6,6	86,6	45,3	31,1	16,2	5,5

Código e nome da série		Energia (kcal)	Proteína (g)	Hidratos de carbono (g)	Açúcares (g)	Gordura (g)	Ácidos gordos saturados (g)	Fibra (g)
MQA134 Tarte alta, c/ fruta	A	179	2,5	26,8	19,9	6,7	3,0	0,3
	B	309	4,3	46,2	34,4	11,5	5,1	0,5
	C	460	6,4	68,8	51,2	17,2	7,6	0,7
	D	639	8,9	95,6	71,1	23,9	10,6	1,0
	E	836	11,7	125,0	93,0	31,2	13,8	1,3
	F	1064	14,8	159,1	118,4	39,8	17,6	1,6
MQA135 Torta, fatias redondas	A	106	1,7	13,1	8,6	5,2	1,3	0,2
	B	204	3,3	25,1	16,5	9,9	2,4	0,4
	C	367	5,9	45,4	29,7	17,9	4,4	0,7
	D	558	8,9	68,9	45,1	27,2	6,7	1,0
	E	841	13,4	103,8	68,0	41,0	10,1	1,5
	F	1151	18,4	142,1	93,0	56,1	13,8	2,1
MQA136 Gelado, vienetta, fatias	A	58	1,0	4,9	5,0	3,7	1,5	0,3
	B	126	2,1	10,7	11,0	8,2	3,2	0,7
	C	186	3,2	15,8	16,3	12,1	4,8	1,0
	D	320	5,4	27,1	27,9	20,7	8,2	1,7
	E	491	8,3	41,5	42,8	31,8	12,6	2,6
MQA137 Pudim	A	145	2,7	25,0	23,4	3,2	0,2	0,0
	B	225	4,2	38,9	36,4	4,9	0,4	0,0
	C	356	6,6	61,5	57,7	7,8	0,6	0,0
	D	552	10,3	95,3	89,3	12,1	0,9	0,0
	E	771	14,3	133,2	124,9	16,9	1,3	0,0
	F	1120	20,8	193,4	181,3	24,5	1,9	0,0
MQA138 Leite creme	A	82	2,0	13,3	12,6	2,3	0,3	0,1
	B	167	4,0	27,0	25,5	4,7	0,5	0,2
	C	290	7,0	47,0	44,3	8,2	0,9	0,3
	D	472	11,4	76,5	72,1	13,3	1,5	0,5
	E	691	16,7	111,9	105,5	19,4	2,2	0,8
	F	977	23,6	158,2	149,2	27,5	3,1	1,1
MQA139 Mousse, prato	A	29	0,6	3,1	3,1	1,5	0,8	0,4
	B	58	1,1	6,3	6,2	3,0	1,7	0,9
	C	128	2,5	13,7	13,6	6,5	3,6	1,9
	D	234	4,6	25,1	24,9	12,0	6,6	3,5
	E	467	9,2	50,2	49,8	23,9	13,3	7,0
	F	935	18,4	100,5	99,5	47,9	26,5	14,0
MQA139B Mousse, taça	A	29	0,6	3,1	3,1	1,5	0,8	0,4
	B	58	1,1	6,3	6,2	3,0	1,7	0,9
	C	128	2,5	13,7	13,6	6,5	3,6	1,9
	D	234	4,6	25,1	24,9	12,0	6,6	3,5
	E	467	9,2	50,2	49,8	23,9	13,3	7,0
	F	935	18,4	100,5	99,5	47,9	26,5	14,0

Código e nome da série		Energia (kcal)	Proteína (g)	Hidratos de carbono (g)	Açúcares (g)	Gordura (g)	Ácidos gordos saturados (g)	Fibra (g)
MQA141 Aletria, prato	A	103	2,2	14,2	10,2	4,1	1,6	0,4
	B	189	4,0	26,1	18,8	7,5	3,0	0,7
	C	359	7,5	49,5	35,6	14,2	5,6	1,3
	D	745	15,6	102,8	73,8	29,5	11,7	2,8
	E	1123	23,5	155,0	111,3	44,5	17,6	4,1
	F	1514	31,7	208,9	150,1	60,0	23,7	5,6
MQA142 Aletria, prato de sobremesa	A	103	2,2	14,2	10,2	4,1	1,6	0,4
	B	194	4,1	26,8	19,2	7,7	3,0	0,7
	C	351	7,4	48,5	34,8	13,9	5,5	1,3
	D	563	11,8	77,7	55,8	22,3	8,8	2,1
	E	840	17,6	116,0	83,3	33,3	13,2	3,1
MQA143 Pipocas	A	19	0,5	3,9	1,2	0,2	0,0	0,2
	B	35	0,9	7,1	2,2	0,3	0,1	0,3
	C	78	2,0	15,7	4,8	0,6	0,2	0,8
	D	136	3,5	27,5	8,4	1,1	0,3	1,3
	E	218	5,5	44,1	13,4	1,7	0,4	2,1
	F	323	8,2	65,3	19,9	2,5	0,7	3,2
MQA094 Quiche	A	121	3,3	6,9	0,6	8,9	4,1	0,3
	B	254	6,9	14,3	1,3	18,5	8,7	0,6
	C	464	12,6	26,2	2,4	33,8	15,8	1,1
	D	758	20,6	42,8	4,0	55,3	25,8	1,8
	E	1211	32,9	68,4	6,3	88,3	41,3	2,9
	F	1800	48,9	101,7	9,4	131,3	61,3	4,4
MQA095 Bola de carne, fatias	A	83	2,1	5,7	0,3	5,3	1,2	0,2
	B	200	5,1	13,7	0,8	12,8	3,0	0,5
	C	355	9,1	24,3	1,5	22,8	5,3	0,9
	D	562	14,4	38,5	2,3	36,1	8,3	1,4
	E	920	23,6	63,1	3,8	59,1	13,7	2,3
	F	1332	34,1	91,3	5,5	85,5	19,8	3,4
MQA096 Tarte salgada, empada	A	57	3,7	6,2	0,6	1,8	0,1	0,5
	B	88	5,6	9,5	0,9	2,8	0,1	0,8
	C	144	9,3	15,7	1,5	4,7	0,2	1,3
	D	266	17,1	28,8	2,7	8,6	0,3	2,4
	E	372	24,0	40,4	3,8	12,0	0,5	3,4
	F	520	33,5	56,4	5,3	16,7	0,7	4,7
	G	822	53,0	89,1	8,4	26,5	1,1	7,5
MQA151 Calzone	A	190	8,6	21,5	3,3	7,2	2,6	1,8
	B	420	19,1	47,5	7,3	15,9	5,8	4,0
	C	678	30,8	76,7	11,9	25,6	9,3	6,4
	D	873	39,7	98,7	15,3	33,0	12,0	8,3

Código e nome da série		Energia (kcal)	Proteína (g)	Hidratos de carbono (g)	Açúcares (g)	Gordura (g)	Ácidos gordos saturados (g)	Fibra (g)
MQA150A Pizza grande	A	185	7,5	19,1	2,9	7,9	2,8	0,7
	B	370	14,9	38,1	5,8	15,8	5,6	1,5
	C	555	22,4	57,2	8,7	23,7	8,3	2,2
	D	740	29,9	76,2	11,6	31,6	11,1	2,9
	E	1480	59,8	152,4	23,3	63,2	22,2	5,8
MQA150B Pizza média	A	107	4,6	9,7	1,4	5,0	1,6	0,6
	B	215	9,2	19,4	2,9	10,0	3,1	1,2
	C	429	18,3	38,9	5,7	20,0	6,3	2,4
	D	644	27,5	58,3	8,6	30,0	9,4	3,5
	E	859	36,7	77,7	11,4	39,9	12,5	4,7

Tabela 4. Volume das medidas caseiras

Código da série	Nome da medida caseira	Volume (mL)			
		$\frac{1}{4}$	$\frac{1}{2}$	$\frac{3}{4}$	1
MC01	A Copo de vinho com pé grande	30	111	215	320
	B Copo de vinho com pé médio	25	78	152	222
	C Copo, cálice (balão) grande	27	81	151	212
	D Copo, cálice (balão) pequeno	13	46	88	129
MC02	A Copo de vinho com pé grande	30	111	215	320
	B Copo, cálice, conhaque, grande	82	196	289	365
	C Copo, cálice, conhaque, médio	39	117	185	239
	D Copo, cálice, conhaque, pequeno	21	60	96	125
MC03	A Copo executivo	57	125	192	270
	B Copo de vinho com pé pequeno	18	57	109	165
	C Copo de vinho com pé médio	25	78	152	222
	D Copo, flute de espumante/champagne	23	69	127	183
MC04	A Copo de vinho com pé médio	25	78	152	222
	B Copo viticole grande	42	106	158	202
	C Copo viticole pequeno	27	56	86	110
	D Copo com pé	34	83	129	172
MC05	A Copo de cerveja	39	126	233	308
	B Copo de cerveja	31	83	155	250
	C Copo de cerveja	24	64	125	203
	D Caneca de cerveja	98	230	368	525
MC06	A <i>Long Drink</i> (tipo longo)	71	154	247	344
	B <i>On the Rocks</i> (tipo curto)	41	89	142	200
	C Copo, <i>shot</i>	4	9	16	23
MC07	A Copo sem pé	48	112	202	310
	B Copo sem pé	48	104	164	236
	C Copo sem pé	34	71	128	186
	D Copo sem pé	33	70	117	176
MC08	A Chávena de café expresso	5	17	29	40
	B Chávena de chá	39	80	124	175
	C Chávena de meia de leite	52	99	157	222
MC09	A Caneca	85	165	239	312
	B Chávena de chá	39	80	124	175
	C Chávena de meia de leite	52	99	157	222
MC10	A Tijela de sopa grande	110	230	370	510
	B Tijela de sopa pequena	85	160	265	350
	C Taça de vidro grande	50	115	185	270
MC11	A Tijela de sopa pequena	85	160	265	350
	B Taça de vidro grande	50	115	185	270
	C Taça de vidro pequena	30	75	115	170



INQUÉRITO ALIMENTAR NACIONAL
E DE ATIVIDADE FÍSICA



